

Part 1 - Dimension Limits

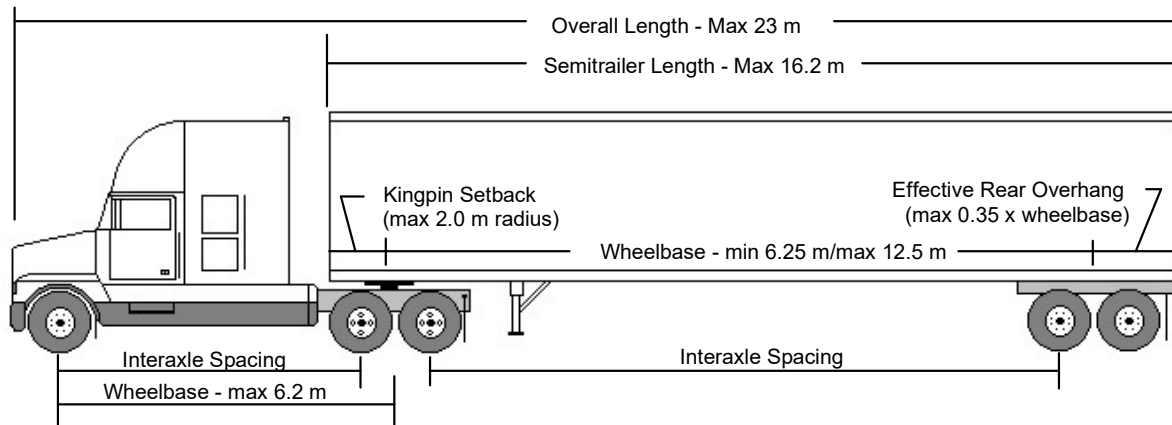

DIMENSION	LIMIT
Overall Length	Maximum 23 m
Overall Width	Maximum 2.6 m
Overall Height	Maximum 4.15 m
Tractor:	
Wheelbase	Maximum 6.2 m
Tandem Axle Spread	Minimum 1.2 m/Maximum 1.85 m
Semi-trailer	
Length	Maximum 16.2 m
Wheelbase	Minimum 6.25 m/Maximum 12.5 m
Kingpin Setback	Maximum 2.0 m radius
Effective Rear Overhang	Maximum 35% of wheelbase
Tandem Axle Spread	Minimum 1.2 m/Maximum 1.85 m
Tridem Axle Spread	Minimum 2.4 m/Maximum 3.7 m
Track Width	Minimum 2.5 m/Maximum 2.6 m
Interaxle Spacings	
Single Axle to Single, Tandem or Tridem Axle	Minimum 3.0 m
Tandem Axle to Tandem Axle	Minimum 5.0 m
Tandem Axle to Tridem Axle	Minimum 5.5 m

Part 2 - Weight Limits

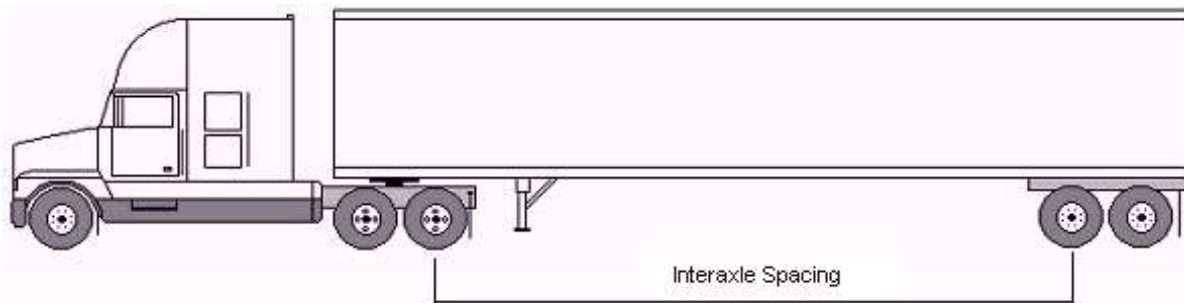

WEIGHT	LIMIT
Axle Weights:	
Steering Axle	Maximum 6000 kg
Carrying Axles:	
Single Axle	
Single tires	Maximum 7300 kg
Wide base single tires	Maximum 9100 kg
Dual tires	Maximum 9100 kg
Tandem Axle:	
Single tires	Maximum 13,600 kg
Wide base single tires	Maximum 17,000 kg
Dual tires	Maximum 17,000 kg
Tridem Axle:	
Single tires	Maximum 19,000 kg
Dual and wide base single tires with axle spread from 2.4 m to less than 3.0 m	Maximum 21,000 kg
Dual and wide base single tires with axle spread from 3.0 m to 3.7 m	Maximum 24,000 kg
Gross Vehicle Weight Limits	
See Weight Calculator https://www.alberta.ca/commercial-vehicle-weight-and-dimensions-regulations.aspx	Cannot exceed the sum of the maximum legal axle weights and is subject to minimum interaxle spacing.

All axle weights are subject to minimum tire size. The maximum weight per tire shall not exceed the lesser of the tire manufacturer's weight rating or the width of the tire stamped on the sidewall multiplied by 10 kg/mm.