

Examples of Descriptions Used in Audio Versions of Science Diploma Exams



Biology 30 / Chemistry 30
Physics 30 / Science 30

This document was written primarily for:

Students	✓
Teachers	✓ of diploma sciences
Administrators	✓
Parents	
General Audience	
Others	

Alberta Education, Government of Alberta

2019–2020

Examples of Descriptions Used in Audio Versions of Science Diploma Exams: Biology 30, Chemistry 30, Physics 30, and Science 30

Distribution: This document is posted on the [Alberta Education website](#).

Copyright 2019, the Crown in Right of Alberta, as represented by the Minister of Education, Alberta Education, Provincial Assessment Sector, 44 Capital Boulevard, 10044 108 Street NW, Edmonton, Alberta T5J 5E6, and its licensors. All rights reserved.

Special permission is granted to **Alberta educators only** to reproduce, for educational purposes and on a non-profit basis, parts of this document that do **not** contain excerpted material.

Excerpted material in this document **shall not** be reproduced without the written permission of the original publisher (see credits, where applicable).

Contents

Introduction	1
Units	2
Unit Prefixes	4
Symbols	5
Numerical Values	6
Chemical Formulas.....	8
Multiple-choice Items.....	9
Numerical-response Items.....	10
Tables.....	17
Graphs	24
Graphs with No Scaled Axes	24
Scaled Graphs with or without Grid Lines	27
Graphs with Multiple Data Lines.....	33
Bar Graphs.....	39
Venn Diagrams.....	41
Heart Diagrams.....	42
Gene Symbols	44
Pedigrees	45
Cell Process Diagrams.....	46
Neuron Diagrams.....	48
Human Brain Diagrams	49
Human Eye Diagrams.....	50
Human Ear Diagrams	51
Feedback Loop Diagrams.....	52
Endocrine System Diagrams	53
Reproductive System Diagrams	54
Human Fetus and Associated Structure Diagrams	56
Organizational Charts.....	57
Micrographs.....	58
Karyotype Diagrams.....	60
Life Cycle Diagrams	61
DNA Diagrams	63

Please note that if you cannot access one of the direct website links referred to in this document, you can find diploma examination-related materials on the [Alberta Education website](#).

Chemical Reaction Equations.....	64
Equilibrium Law Expressions.....	65
Enthalpy Notation.....	65
Redox Notation.....	65
Molecular Structures	66
Electrochemical Cell Diagrams.....	69
Fractional Distillation Tower Diagrams.....	70
Titration Apparatus Diagrams.....	71
WHMIS Pictograms	72
Nuclear Equations	74
Isotopes	74
Field Line Diagrams.....	75
Circuit Diagrams.....	76
Transformer Diagrams.....	80
Motor Diagrams.....	81
Spectra Diagrams.....	82
Power Plant Diagrams.....	83
Phases of the Moon Diagrams	85
Directions.....	86
Ruler Diagrams	86
Unit Analysis	87
Two-dimensional Collision Diagrams	88
Particle Tracks	89
Charged Sphere Diagrams.....	90
Solenoid Diagrams	90
Energy Level Diagrams	91
Michelson Apparatus Diagrams	92
Charged Plates.....	93

Introduction

This document has been prepared by the Provincial Assessment Sector of Alberta Education. Its purpose is to provide school staff with examples of the descriptions of diagrams, illustrations, visuals, and questions used in diploma exam audio versions, which are available to students as an accommodation. Included here are both examples for content that is common across the science diploma subjects (Biology 30, Chemistry 30, Physics 30, and Science 30) and examples that are specific to particular science diploma exams. The descriptions and terminology used may differ between subject disciplines. These examples are neither exhaustive nor prescriptive. Exam content is shown in black text and descriptions in blue text.

For students who are enrolled with a school, and who typically use audio for their coursework, no application is required to receive this accommodation when writing diploma exams. Such students may have visual impairments, physical disabilities, or learning disabilities. The audio version is used by students in conjunction with a print, digital, or Braille version of the exam.

Additional information on how to prepare for diploma exams can be found on the Alberta Education website at education.alberta.ca.

Units

Unit	Read as
s	seconds
min	minutes
d	days
h	hours
yr	years
/a	per annum
/yr	per year
AU or au	astronomical units
m	metres
m ²	square metres
ha	hectares
m ³	cubic metres
L	litres
mmHg	millimetres of mercury
m/s	metres per second
km/h	kilometres per hour
m/s ²	metres per second squared
g	grams
t	tonnes
mol	moles
g/mol	grams per mole
mol/L	moles per litre
ppm	parts per million
g/L	grams per litre
g/cm ³	grams per cubic centimetre
Pa	pascals
K	kelvin
°C	degrees Celsius

Unit	Read as
J/(g·°C)	joules per gram-degrees Celsius
J/(g·K)	joules per gram-kelvin
Hz	hertz
V	volts
A	amperes
Ω	ohms
C	coulombs
C/s	coulombs per second
eV	electron volts
eV·s	electron volt-seconds
W	watts
J	joules
J·s	joule-seconds
J/C	joules per coulomb
kW·h	kilowatt-hours
toe	tonnes of oil equivalent
BTU or btu	British thermal units
GtCO ₂	gigatonnes of carbon dioxide
kJ/mol	kilojoules per mole
N	newtons
N·s	newton-seconds
N/kg	newtons per kilogram
N/C	newtons per coulomb
N·m ² /C ²	newton-square metres per coulomb squared
N·m ² /kg ²	newton-square metres per kilogram squared
kg·m/s	kilogram-metres per second
T	teslas

Note: This table includes SI units and non-SI units. Names of SI base units and SI-derived units are from National Institute of Standards and Technology, 2019.

Unit Prefixes

Unit Prefix	Read as
P	peta
T	tera
G	giga
M	mega
k	kilo
h	hecto
da	deca
m	milli
d	deci
c	centi
μ	micro
n	nano
p	pico

Symbols

Symbols	Read as
α	Alpha
β	Beta
γ	Gamma
Δ	Delta or “change in”
λ	Lambda
μ	Mu
Σ	Sigma or “sum of”
+	Plus
-	Minus
\pm	Plus or minus
\div	Divided by
\times	Times
<	Is less than
>	Is greater than
=	Is equal to
$^{\circ}$	Degrees or standard
\$	Dollars
¢	Cents
%	Percent
\rightarrow	Produces
\rightleftharpoons	Is in equilibrium with

Numerical Values

Numerical Value	Read as
183.48	one hundred eighty-three decimal four eight
2 321	two thousand three hundred twenty-one
$\frac{3}{5}$	three over five
-5	negative five
+5	positive five
± 5	positive or negative five
2.21×10^{17}	two decimal two one times ten to the exponent seventeen
3.6×10^{-7}	three decimal six times ten to the exponent negative seven

Note: Common fractions, such as $\frac{1}{2}$, may be read as “one over two” or “one half.”

The following example of student work illustrates units, symbols, numerical values, and mathematical operations.

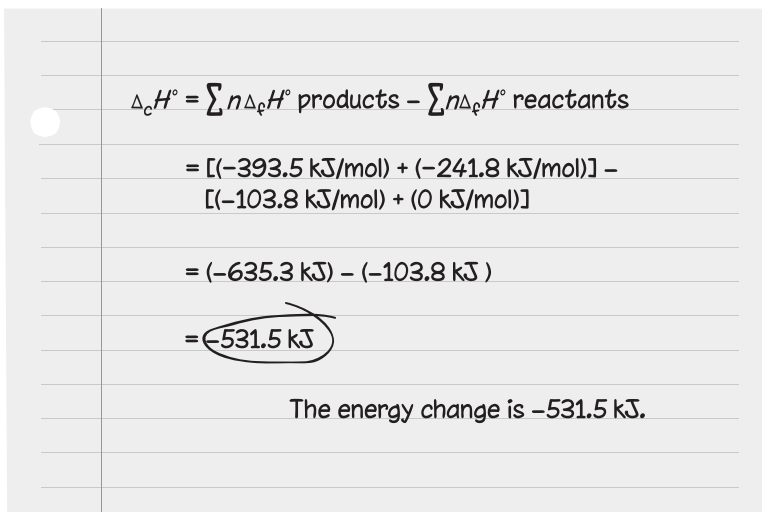
$$\begin{aligned}\Delta_c H^\circ &= \sum n \Delta_f H^\circ \text{ products} - \sum n \Delta_f H^\circ \text{ reactants} \\ &= [(-393.5 \text{ kJ/mol}) + (-241.8 \text{ kJ/mol})] - \\ &\quad [(-103.8 \text{ kJ/mol}) + (0 \text{ kJ/mol})] \\ &= (-635.3 \text{ kJ}) - (-103.8 \text{ kJ}) \\ &= -531.5 \text{ kJ}\end{aligned}$$

The energy change is -531.5 kJ .

Delta C H standard is equal to the sum of n delta F H standard products minus the sum of n delta F H standard reactants

Is equal to: open square bracket, open bracket, negative three hundred ninety-three decimal five kilojoules per mol, closed bracket, plus, open bracket negative two hundred forty-one decimal eight kilojoules per mol, closed bracket, closed square bracket, minus, open square bracket, open bracket, negative one hundred three decimal eight kilojoules per mol, closed bracket, plus, open bracket zero kilojoules per mol closed bracket, closed square bracket.

Is equal to: open bracket negative six hundred thirty-five decimal three kilojoules, closed bracket, minus, open bracket negative one hundred three decimal eight kilojoules, closed bracket.

Is equal to: negative five hundred thirty-one decimal five kilojoules. This answer is circled by the student and the student has written "The energy change is negative five hundred thirty-one decimal five kilojoules."

Chemical Formulas

Chemical Formula	Read as
Fe(s)	F E solid
Mg(s)	M G solid
Fe ²⁺ (aq)	F E two positive aqueous
H ₂ O(l)	H two O liquid
Ni ₂ O ₃ (s)	N I two O three solid
SO ₄ ²⁻ (aq)	S O subscript four, superscript two negative aqueous
PO ₄ ³⁻ (aq)	P O subscript four, superscript three negative aqueous
(NH ₄) ₂ S(aq)	open bracket N H four closed bracket two S aqueous

Note: Read “subscript” and “superscript” only when a formula has **both** subscripted numbers indicating the number of atoms in the species and superscripted numbers indicating the ion charge (e.g., PO₄³⁻).

Multiple-choice Items

This examination is for the subject of

- A. chemistry
- B. biology
- C. physics
- D. science

Answer: D

Record D on the answer sheet: Ⓐ Ⓑ Ⓒ ●

On the answer sheet, you will find the letters A, B, C and D each written in a circle. The circle containing the letter D has been completely filled in as the correct response to this question.

Sequencing Question and Solution

Four Subjects	
1	Physics
2	Biology
3	Science
4	Chemistry

When the subjects above are arranged in alphabetical order, their order is _____, _____, _____, and _____.

(Record all **four digits** of your answer in the numerical-response section on the answer sheet.)

Answer: 2413

Record 2413 on the answer sheet

→

2	4	1	3
---	---	---	---

Fill in the corresponding circles

	0	0	0	0
	1	1	1	1
	2	2	2	2
	3	3	3	3
	4	4	4	4
	5	5	5	5
	6	6	6	6
	7	7	7	7
	8	8	8	8
	9	9	9	9

There is a list titled “Four subjects.”

One: physics, Two: biology, Three: science, Four: chemistry.

When the subjects above are arranged in alphabetical order, their order is blank, blank, blank, and blank.

Record all **four digits** of your answer in the numerical-response section on the answer sheet.

Answer: two four one three.

Record two four one three on the answer sheet and fill in the corresponding circles using the previous instructions.

Selection Question and Solution

Five Subjects	
1	Art
2	Music
3	Physics
4	Biology
5	Chemistry

The science subjects in the list above are numbered _____, _____, and _____.

(Record all **three digits** of your answer **in any order** in the numerical-response section on the answer sheet.)

Answer: 345

Record 345 on the answer sheet →

	3	4	5	
	•	•		
Fill in the corresponding circles	0	0	0	0
	1	1	1	1
	2	2	2	2
	3	3	3	3
	4	4	4	4
	5	5	5	5
	6	6	6	6
	7	7	7	7
	8	8	8	8
	9	9	9	9

Note: All answers containing only the three digits 3, 4, and 5, in any order, will be scored as correct.

There is a list titled “Five Subjects.”

One: art; Two: music; Three: physics; Four: biology; Five: chemistry

The science subjects in the list above are numbered blank, blank, and blank.

Record all **three digits** of your answer **in any order** in the numerical-response section on the answer sheet.

Answer: three four five.

Record three four five on the answer sheet and fill in the corresponding circles using the previous instructions.

Note: All answers containing only the three digits three four and five, in any order, will be scored as correct.

Scientific-notation Question and Solution

The speed of EMR is $a.bc \times 10^d$ m/s. The values of a , b , c , and d are _____, _____, _____, and _____.

(Record all **four digits** of your answer in the numerical-response section on the answer sheet.)

Answer: 3.00×10^8 m/s

Record 3008 on the answer sheet

	3	0	0	8
	•	•		
Fill in the corresponding circles	0	●	●	0
	1	1	1	1
	2	2	2	2
	●	3	3	3
	4	4	4	4
	5	5	5	5
	6	6	6	6
	7	7	7	7
	8	8	8	●
	9	9	9	9

The speed of EMR is a decimal b c times 10 exponent d metres per second. The values of a , b , c , and d are first blank: a , second blank: b , third blank: c , and fourth blank: d .

Record all **four digits** of your answer in the numerical-response section on the answer sheet.

Answer three decimal zero zero times ten exponent eight metres per second.

Record three, zero, zero, eight on the answer sheet and fill in the corresponding circles using the previous instructions.

Using the numbers above, choose **one continent** and match it with a country in that continent and with that country's capital city. (There is more than one correct answer.)

Number: first blank, continent

Number: second blank, country

Number: third blank, capital city

Record all **three digits** of your answer in the numerical-response section on the answer sheet.

Answer: one six eight, or two four nine, or three five seven

Record one six eight on the answer sheet and fill in the corresponding circles using the previous instructions.

Note: The answers one six eight, two four nine, or three five seven will be scored as correct.

Ratio Question and Solution

A collection of marbles includes eight green marbles, four blue marbles, and two white marbles.

What is the colour ratio of the marbles in the collection?

Ratio: _____ : _____ : _____
Colour: Green Blue White

(Record all **three digits** of your answer in the numerical-response section on the answer sheet.)

Answer: 421

Record 421 on the answer sheet

→

4	2	1	
---	---	---	--

Fill in the corresponding circles

•	•		
0	0	0	0
1	1	●	1
2	●	2	2
3	3	3	3
●	4	4	4
5	5	5	5
6	6	6	6
7	7	7	7
8	8	8	8
9	9	9	9

Ratio: First blank, Colour: green, to second blank, blue, to third blank, white.

Record 421 on the answer sheet and fill in the corresponding circles using the previous instructions.

Tables

Introduce the table starting with the title, and then identify the number of columns and rows. Tables can be read in two different ways. One way is to list the column headings and any corresponding units first. Next, read across each row from left to right, stating the column heading before reading the data in each cell. Read empty spaces in tables as “blank.”

Comparison of Different Brands of Solar Panels

Brand of Solar Panel	Surface Area of Solar Panel (m²)	Solar Radiation Input Power (W/m²)	Total Input Power (W)	Total Output Power (W)	Efficiency (%)
W	2.15	900		464	
X	2.58	900		603	
Y	3.08	900		832	
Z	3.60	900		648	

There is a table titled “Comparison of Different Brands of Solar Panels” with six columns and four rows. The column headings are “Brand of Solar Panel,” “Surface Area of Solar Panel” in square metres, “Solar Radiation Input Power” in watts per square meter, “Total Input Power” in watts, “Total Output Power” in watts, and “Efficiency” in percent. The information in the table is as follows:

Brand of Solar Panel: W; Surface Area of Solar Panel: two decimal one five; Solar Radiation Input Power: nine hundred; Total Input Power: blank; Total Output Power: four hundred sixty four; Efficiency: blank.

Brand of Solar Panel: X; Surface Area of Solar Panel: two decimal five eight; Solar Radiation Input Power: nine hundred; Total Input Power: blank; Total Output Power: six hundred three; Efficiency: blank.

Brand of Solar Panel: Y; Surface Area of Solar Panel: three decimal zero eight; Solar Radiation Input Power: nine hundred; Total Input Power: blank; Total Output Power: eight hundred thirty two; Efficiency: blank.

Brand of Solar Panel: Z; Surface Area of Solar Panel: three decimal six zero; Solar Radiation Input Power: nine hundred; Total Input Power: blank; Total Output Power: six hundred forty eight; Efficiency: blank.

Comparison of Soil pH Before and After Addition of 10 mL of a Strong Acid

Soil Sample	Source of Soil Sample	Initial Soil pH	Soil pH After Addition of Acid
1	Beach in Nova Scotia	7.0	3.5
2	Mountain in Alberta	7.8	7.5
3	Forest in Ontario	6.5	3.8
4	Farm in Saskatchewan	6.0	5.5

There is a table titled “Comparison of Soil pH Before and After Addition of ten millilitres of a Strong Acid” with four columns and four rows. The column headings are “Soil sample,” “Source of Soil Sample,” “Initial Soil pH,” and “Soil pH After Addition of Acid.” The information in the table is as follows:

Soil Sample: One; Source of Soil Sample: Beach in Nova Scotia; Initial Soil pH: seven decimal zero; Soil pH After Addition of Acid: three decimal five.

Soil Sample: Two; Source of Soil Sample: Mountain in Alberta; Initial Soil pH: seven decimal eight; Soil pH After Addition of Acid: seven decimal five.

Soil Sample: Three; Source of Soil Sample: Forest in Ontario; Initial Soil pH: six decimal five; Soil pH After Addition of Acid: three decimal eight.

Soil Sample: Four; Source of Soil Sample: Farm in Saskatchewan; Initial Soil pH: six decimal zero; Soil pH After Addition of Acid: five decimal five.

Some Common Substances

Chemical Name	Chemical Formula	Common Name
Iron	Fe(s)	Iron
Sucrose	C ₁₂ H ₂₂ O ₁₁ (s)	Table sugar
Sodium chloride	NaCl(s)	Table salt
Magnesium hydroxide	Mg(OH) ₂ (s)	Milk of magnesia

There is a table titled “Some Common Substances,” with three columns and four rows. The column headings are “Chemical Name,” “Chemical Formula,” and “Common Name.” The information in the table is as follows:

Chemical Name: Iron; Chemical Formula: F E solid; Common Name: iron

Chemical Name: sucrose; Chemical Formula: C twelve H twenty-two O eleven solid;
Common Name: table sugar

Chemical Name: sodium chloride; Chemical Formula: N A C L solid;
Common Name: table salt

Chemical Name: Magnesium hydroxide;
Chemical Formula: M G open bracket O H closed bracket two solid;
Common Name: Milk of magnesia

	Earth	Mars
Distance from the Sun	1.0 AU (astronomical unit) (150 000 000 km)	1.5 AU (astronomical unit) (225 000 000 km)
Time required for radio waves to travel from the Sun	8.3 min	?

There is a table with two columns and two rows. The column headings are “Earth” and “Mars.” The row headings are “Distance from the Sun” and “Time required for radio waves to travel from the Sun.” The information in the table is as follows:

Distance from the Sun: Earth – One A U, or astronomical unit, or one hundred fifty million kilometers; Mars – one decimal five A U or astronomical units or two hundred twenty-five million kilometers.

Time required for radio waves to travel from the Sun: Earth – eight decimal three minutes; Mars – question mark.

	Pd(s)	Zr(s)	In(s)	Ir(s)
Pd²⁺(aq)	×	✓	✓	×
Zr⁴⁺(aq)	×	×	×	×
In³⁺(aq)	×	✓	×	×
Ir³⁺(aq)	✓	✓	✓	×

- ✓ evidence of a spontaneous reaction
- × no evidence of a spontaneous reaction

There is a table with four columns and four rows. The column headings are “P D solid,” “Z R solid,” “I N solid,” and “I R solid.” The row headings are “P D two positive aqueous,” “Z R four positive aqueous,” “I N three positive aqueous,” and “I R three positive aqueous.”

Below the table, there is a legend that states that a checkmark represents evidence of a spontaneous reaction, and an X represents no spontaneous reaction. The information in the table is as follows:

P D two positive aqueous does not react with P D solid, reacts with Z R solid, reacts with I N solid, and does not react with I R solid.

Z R four positive aqueous does not react with any of the solids.

I N three positive aqueous does not react with P D solid, reacts with Z R solid, does not react with I N solid, and does not react with I R solid.

I R three positive aqueous reacts with P D solid, reacts with Z R solid, reacts with I N solid, and does not react with I R solid.

Another way to read tables is to first list the row headings and any corresponding units. Next, read down each column from top to bottom, stating the row heading before reading the data in each cell. Read Roman numerals as Arabic numerals (e.g., Read “I” as “one” and “IV” as “four.”).

Trial	I	II	III	IV
Final burette reading (mL)	16.08	31.24	46.41	61.59
Initial burette reading (mL)	0.00	16.08	31.24	46.41

There is a table with four columns and three rows. The columns are titled “One,” “Two,” “Three,” and “Four.” The row headings are “Trial,” “Final burette reading in millilitres,” and “Initial burette reading in millilitres.” The information in the table is as follows:

Trial: One; final burette reading: sixteen decimal zero eight; initial burette reading: zero decimal zero zero

Trial: Two; final burette reading: thirty-one decimal two four; initial burette reading: sixteen decimal zero eight

Trial: Three; final burette reading: forty six decimal four one; initial burette reading: thirty one decimal two four

Trial: Four; final burette reading: sixty one decimal five nine; initial burette reading: forty six decimal four one

Phase of Cell Cycle	Number of Cells			
	Site I	Site II	Site III	Total
Interphase	171	167	173	511
Prophase	13	17	5	35
Metaphase	8	6	8	22
Anaphase	5	7	7	19
Telophase	3	9	8	20

There is a table with two columns and five rows. The column headings are “Phase of Cell Cycle” and “Number of Cells.” The “Number of Cells” column has four sub-columns: “Site One,” “Site Two,” “Site Three,” and “Total.” The information in the table is as follows:

Phase of Cell Cycle: Interphase; Number of cells at site one: one hundred seventy-one; at site two: one hundred sixty-seven; and at site three: one hundred seventy-three; Total: five hundred eleven.

Phase of Cell Cycle: Prophase; Number of cells at site one: thirteen; at site two: seventeen; and at site three: five; Total: thirty-five.

Phase of Cell Cycle: Metaphase; Number of cells at site one: eight; at site two: six; and at site three: eight; Total: twenty-two.

Phase of Cell Cycle: Anaphase; Number of cells at site one: five; at site two: seven; and at site three: seven; Total: nineteen.

Phase of Cell Cycle: Telophase; Number of cells at site one: three; at site two: nine; and at site three: eight; Total: twenty.

For certain tables, such as those found in multiple-answer matching questions, read the information down each column, rather than across rows.

Energy Source	Disadvantage of Energy Source	Advantage of Energy Source
1 Fusion	4 Few suitable locations	7 Reliable and relatively inexpensive
2 Wind	5 Technology is only in experimental stage	8 Renewable
3 Coal	6 Non-renewable	9 No carbon dioxide emissions

There is a table with three columns titled “Energy Source,” “Disadvantage of Energy Source,” and “Advantage of Energy Source.”

Energy Source: One, Fusion; Two, Wind; Three, Coal

Disadvantage of Energy Source: Four, Few suitable locations; Five, Technology is only in experimental stage; Six, Non-renewable

Advantage of Energy Source: Seven, Reliable and relatively inexpensive; Eight, Renewable; Nine, No carbon dioxide emissions

Graphs

Introduce the graph starting with the title, if there is one, and then describe the labels and scales for the horizontal axis and the vertical axis. If there are no marks or scale on the axis, state so. To describe the shape of the line representing the data, reference the axis and use descriptive words such as *top*, *bottom*, *right*, *left*, *downward*, *upward*, *rises*, and *falls*. When there are four graphs for each of the multiple-choice options (A, B, C, and D), describe the labels and scales for the similarities between the graphs, such as the horizontal axis and the vertical axis, and then describe the shape of the line for each of the choices.

Graphs with No Scaled Axes

Relationship Between Pesticide Application and Insect Death

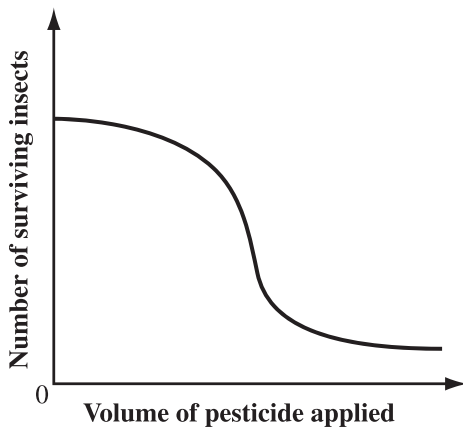

There is a graph titled “Relationship Between Pesticide Application and Insect Death.” The horizontal axis is labelled “Volume of pesticide applied” and the vertical axis is labelled “Number of surviving insects.” There are no marks or scale on the axes.

The line starts nearly horizontal close to the top left of the graph and curves downward until the line is nearly vertical at approximately the centre of the graph. The line then begins to curve upward until it is nearly horizontal close to the bottom right of the graph.

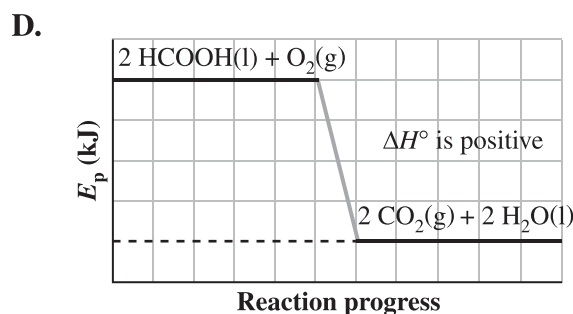
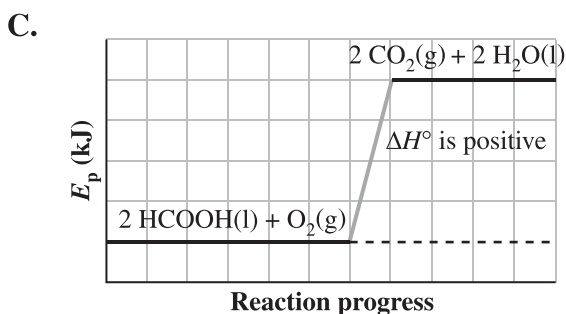
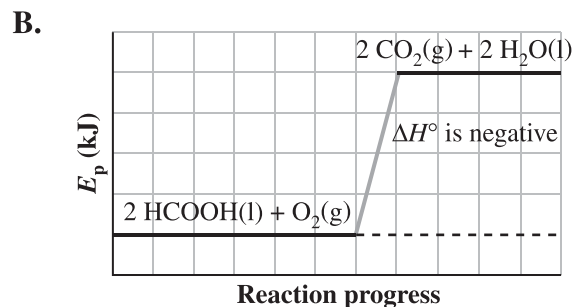
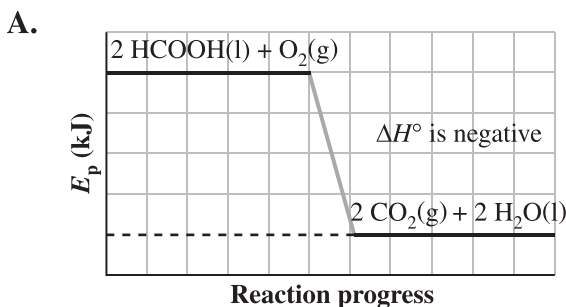

For each choice, there is a graph with the horizontal axis labelled “Reaction progress” and the vertical axis labelled “EP” in kilojoules. Neither axis is marked or scaled. There are two horizontal lines on each graph, joined by a grey, diagonal line. The first horizontal line, on the left side of the graph, is labelled “Two H C O O H liquid plus O two gas.” The second horizontal line, on the right side of the graph, is labelled “Two C O two gas plus two H two O liquid.”

Choice A: The first horizontal line is near the top of the vertical axis, and the second horizontal line is near the bottom of the vertical axis. Delta H standard is negative.

Choice B: The first horizontal line is near the bottom of the vertical axis, and the second horizontal line is near the top of the vertical axis. Delta H standard is negative.

Choice C: The first horizontal line is near the bottom of the vertical axis, and the second horizontal line is near the top of the vertical axis. Delta H standard is positive.

Choice D: The first horizontal line is near the top of the vertical axis, and the second horizontal line is near the bottom of the vertical axis. Delta H standard is positive.

A.

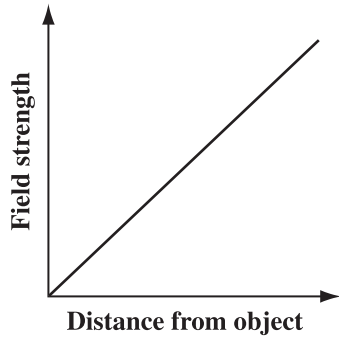

B.

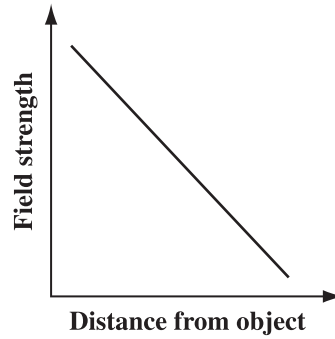

C.

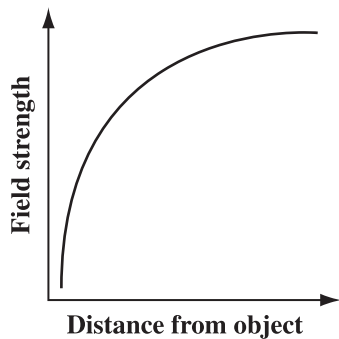

D.

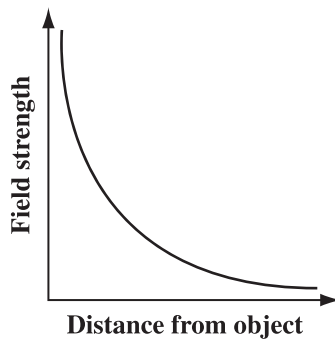

For each choice, there is a graph with the horizontal axis titled "Distance from object" and the vertical axis titled "Field strength." Neither axis is marked or scaled.

Choice A shows a straight line starting at the origin and rising diagonally to the upper right.

Choice B shows a straight line starting near the top left of the graph and falling diagonally to the bottom right.

Choice C shows a curved line starting near the bottom left, rising almost vertically upward, and then curving to the right until it is almost horizontal near the top right of the graph.

Choice D shows a curved line starting near the upper left, falling almost vertically downward, and then curving to the right until it is almost horizontal near the bottom right of the graph.

Read a comma in descriptions only when the comma separates numbers given as coordinates.

Scaled Graphs with or without Grid Lines

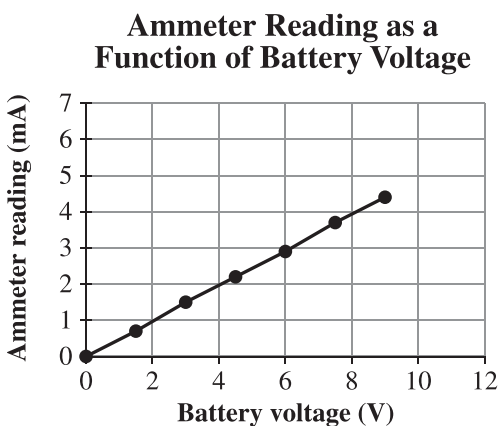

There is a graph titled “Ammeter Reading as a Function of Battery Voltage.” The horizontal axis is labelled “Battery Voltage” in volts, scaled from zero to twelve, and marked and labelled in increments of two. The vertical axis is labelled “Ammeter reading” in milliamps, scaled from zero to seven, and marked and labelled in increments of one. The line starts at the origin and is a straight diagonal line that rises to the right. The following points are marked on the line: zero comma zero; one decimal five comma zero decimal seven; three decimal zero comma one decimal five; four decimal five comma two decimal two; six decimal zero comma two decimal nine; seven decimal five comma three decimal seven; and nine decimal zero comma four decimal four.

Activity as a Function of Time for a Sample of Barium-137

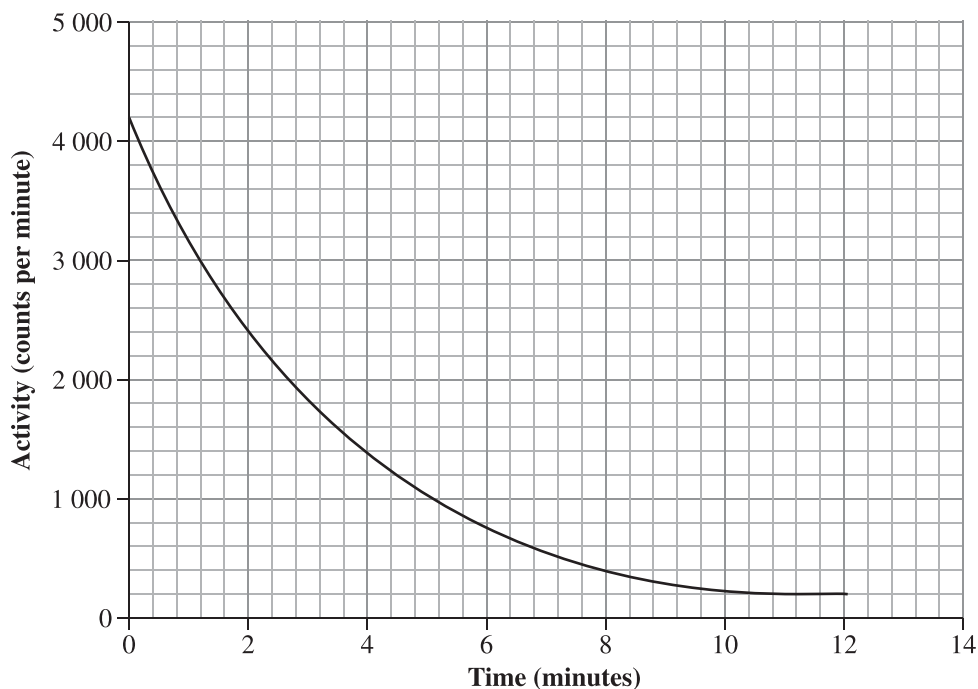

There is a graph titled “Activity as a Function of Time for a Sample of Barium one hundred thirty-seven.”

The horizontal axis is labelled “Time” in minutes, scaled from zero to fourteen, and marked and labelled in increments of two. The vertical axis is labelled “Activity” in counts per minute, scaled from zero to five thousand, and marked and labelled in increments of one thousand.

The graph shows a curve that begins at zero comma four thousand two hundred and falls to the right. The curve goes through the following coordinates: two comma two thousand four hundred; four comma one thousand four hundred; eight comma four hundred; and, twelve comma two hundred.

Temperature of a Solution During a Chemical Reaction

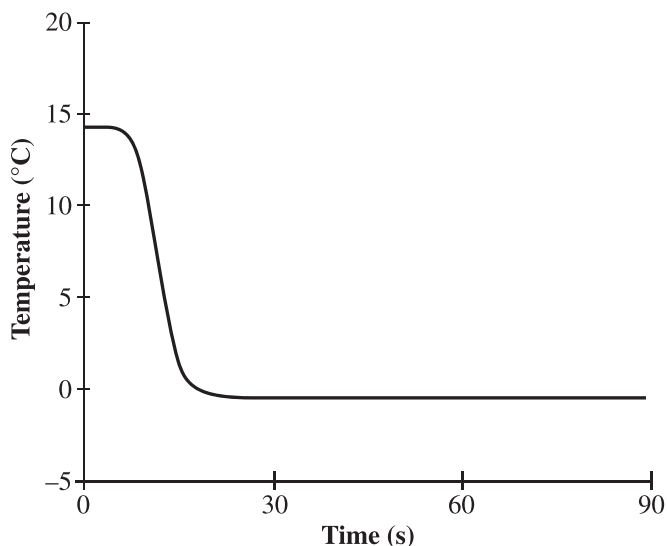

There is a graph titled “Temperature of a Solution During a Chemical Reaction.” The horizontal axis is labelled “Time” in seconds, scaled from zero to ninety, and marked and labelled in increments of thirty. The vertical axis is labelled “Temperature” in degrees Celsius, scaled from negative five to twenty, and marked and labelled in increments of five. The line begins on the vertical axis at approximately fourteen degrees Celsius. It then falls at approximately ten seconds to become almost vertical. It then becomes horizontal, once again, at approximately twenty seconds and zero degrees Celsius and remains horizontal until it reaches the right side of the graph.

Growth of a Population of *Daphnia*

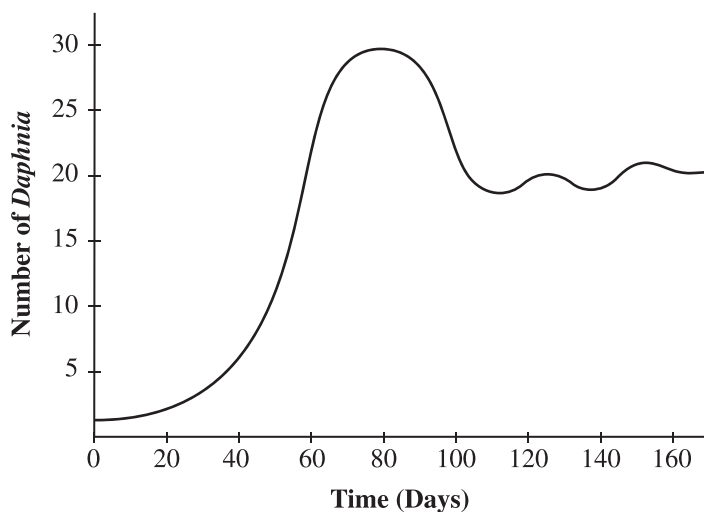

There is a graph titled “Growth of a Population of *Daphnia*.”

The horizontal axis is labelled “Time” in days, scaled from zero to one hundred sixty, and marked and labelled in increments of twenty.

The vertical axis is labelled “Number of *Daphnia*,” scaled from zero to thirty, and marked and labelled in increments of five.

The line begins on the vertical axis just above the origin. The line curves upward and to the right, very gradually at first and then more steeply. The line peaks at approximately eighty days and thirty *Daphnia* before curving steeply downward until approximately one hundred days and twenty *Daphnia*. The line then continues horizontally, fluctuating at approximately twenty *Daphnia*.

Titration Curve

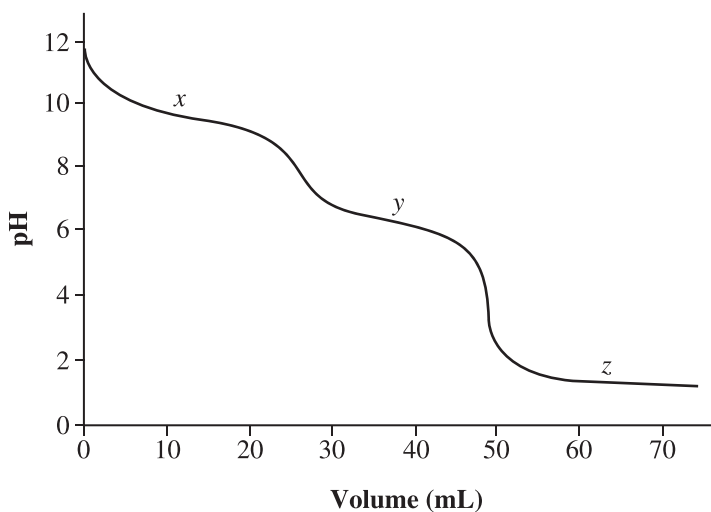

There is a graph titled “Titration Curve.” The horizontal axis is labelled “Volume” in millilitres, scaled from zero to seventy, and marked and labelled in increments of ten. The vertical axis is labelled “pH,” scaled from zero to twelve, and marked and labelled in increments of two.

The curve starts on the vertical axis at approximately eleven decimal eight, falls steeply to approximately a volume of eight and pH of ten, and then falls more gradually to approximately a volume of twenty-five and pH of nine. This region of the curve is labelled *x*. The curve then falls steeply to approximately a volume of thirty and pH of six, and again falls more gradually to approximately a volume of fifty and pH of five. This region of the curve is labelled *y*. The curve then falls steeply to approximately a volume of fifty-two and pH of two, and finally becomes almost horizontal at a pH just below two. This region of the curve is labelled *z*.

Force as a Function of Time

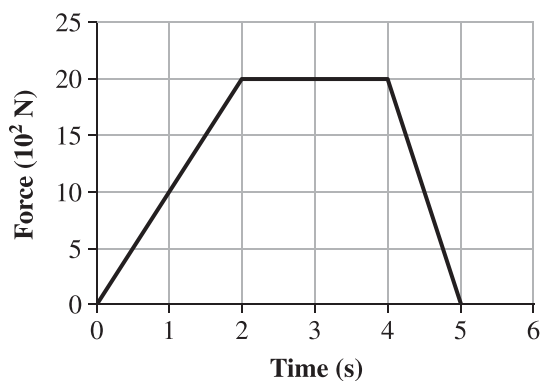

There is a graph titled “Force as a Function of Time.” The horizontal axis is labelled “Time” in seconds, scaled from zero to six, and marked and labelled in increments of one. The vertical axis is labelled “Force” in ten exponent two newtons, scaled from zero to twenty-five, and marked and labelled in increments of five.

The line begins at zero comma zero, rises diagonally to two comma twenty, continues horizontally to four comma twenty, then falls diagonally to five comma zero.

Graphs with Multiple Data Lines

Introduce the graph starting with the title, then describe the label and scale for the horizontal axis, and then describe the label and scale for the vertical axis. Identify the number of lines representing data on the graph and describe how each line is represented (e.g., solid line, dashed line, blue line, etc.). Describe any line labels or legend. Identify whether the lines have the same starting point or different starting points. To describe the shape of the data lines, reference the axis and use descriptive words such as *top*, *bottom*, *right*, *left*, *downward*, *upward*, *falls*, and *rises*.

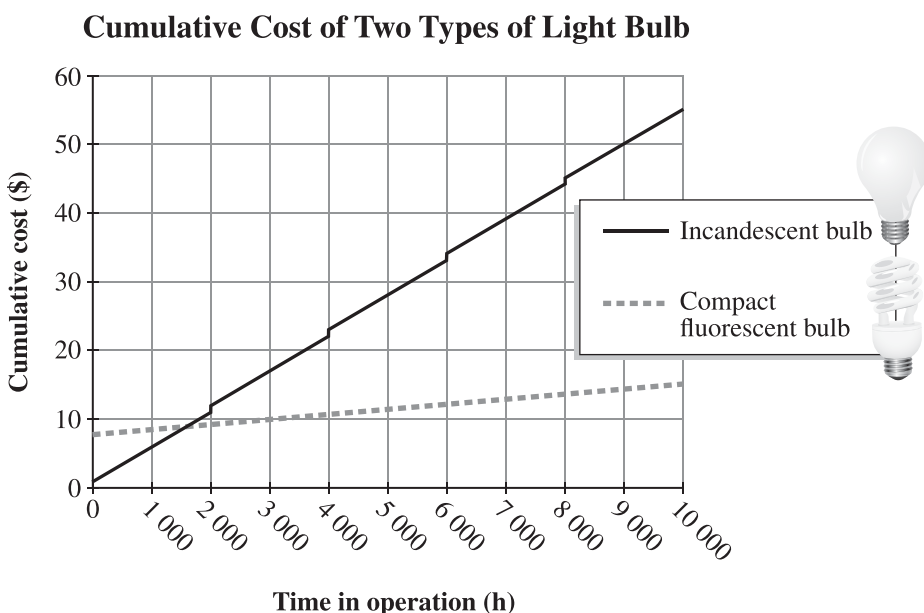

There is a graph titled “Cumulative Cost of Two Types of Light Bulb.” The horizontal axis is labelled “Time in operation” in hours, scaled from zero to ten thousand, and marked and labelled in increments of one thousand. The vertical axis is labelled “Cumulative cost in dollars,” scaled from zero to sixty, and marked and labelled in increments of ten.

Two data lines are shown. A legend shows that the solid data line represents an incandescent bulb and a dashed line represents a compact fluorescent bulb. The solid line starts at zero hours and approximately one dollar. This line rises diagonally toward the upper right with a vertical rise of one dollar every two thousand hours. The solid line ends at ten thousand hours and fifty-five dollars. The dashed line starts at zero hours and approximately nine dollars, then gradually rises diagonally toward the right, ending at approximately ten thousand hours and fifteen dollars.

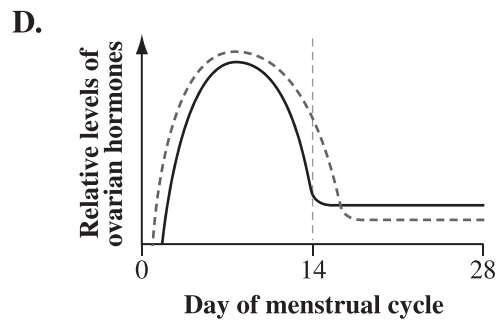
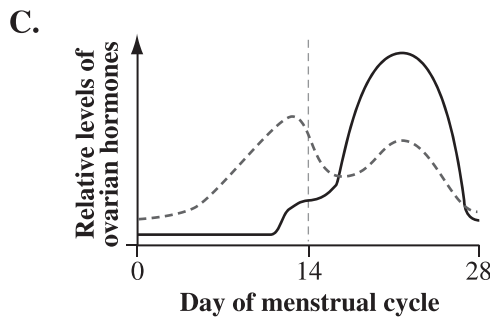
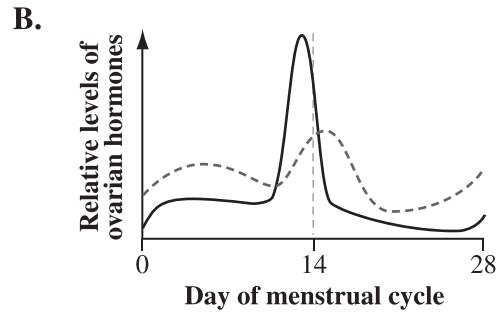
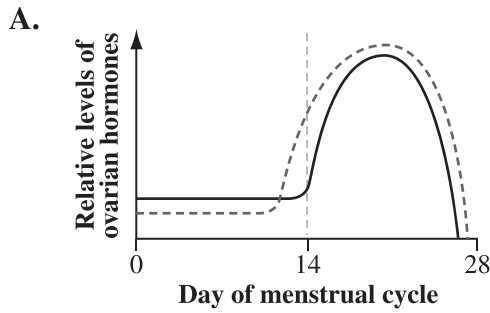

For each choice, there is a graph with the horizontal axis labelled “Day of menstrual cycle,” scaled from zero to twenty-eight, and marked and labelled in increments of fourteen. A vertical dashed line intersects the horizontal axis at day fourteen. The vertical axis is labelled “Relative levels of ovarian hormones” and is not marked or scaled. Each graph has two lines, one solid and one dashed. Each line represents a different hormone.

Choice A: The dashed line begins at a low level on day zero and continues horizontally until it begins to rise sharply at approximately day twelve. It continues to rise until reaching a peak midway between days fourteen and twenty-eight, and then falls until it reaches the horizontal axis at day twenty-eight.

The solid line begins at a low level on day zero and continues horizontally until approximately day fourteen, when it begins to rise sharply. It reaches a peak just below the dashed line midway between days fourteen and twenty-eight, and then falls until it reaches the horizontal axis at day twenty-eight.

Choice B: The dashed line begins at a low level on day zero and increases gradually until it peaks at approximately day five, and then decreases gradually until approximately day twelve. The line then increases more steeply until it forms a slightly taller peak at approximately day fifteen. It decreases until it reaches its lowest point at approximately day twenty, and then rises gradually again until day twenty-eight.

The solid line begins at a very low level on day zero, and then rises slightly until approximately day two, when it flattens out. At approximately day ten, the line rises sharply, reaches a peak at approximately day thirteen, and then falls sharply to a low level at approximately day fifteen. It continues to decrease slowly until approximately day twenty-seven, when it starts to rise slightly again.

Choice C: The dashed line begins at a low level on day zero. It rises steadily until it reaches a peak at approximately day thirteen. The line then falls slightly until about approximately day fifteen, when it starts to rise again to form a second peak between days nineteen and twenty-three. It then falls sharply to a very low level at day twenty-eight.

The solid line begins at a very low level on day zero and continues horizontally until approximately day twelve. It rises moderately until approximately day fifteen, when it rises sharply to form a peak between days sixteen and twenty-three. It then falls sharply to a very low level at day twenty-eight.

Choice D: The dashed line begins at a low level on approximately day one and rises sharply until it forms a peak at approximately day seven. It then falls sharply to a low level by approximately day fifteen and continues horizontally through day twenty-eight.

The solid line begins at a low level on approximately day two and rises sharply until it forms a peak at approximately day seven just below the dashed line. It then falls sharply to a low level by day fourteen and continues horizontally through day twenty-eight.

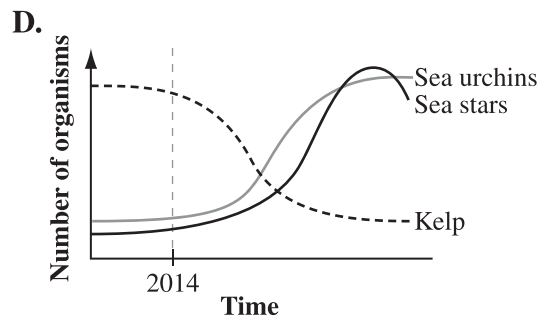
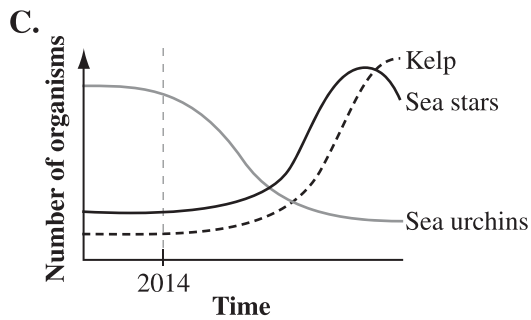
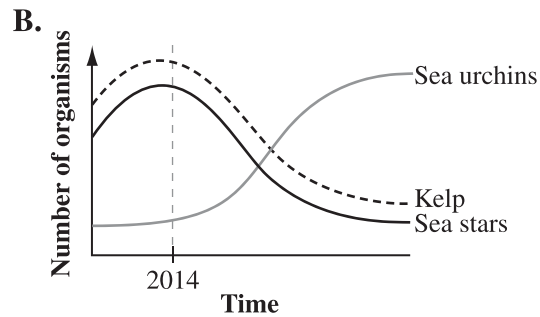
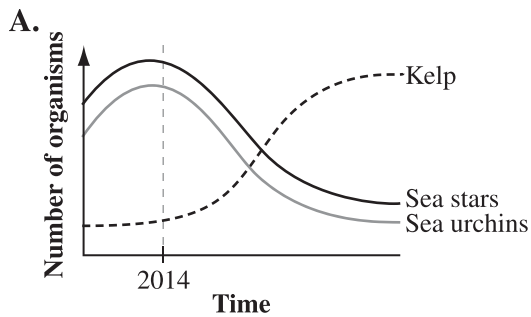

For each choice, there is a graph with the horizontal axis labelled “Time” and the year 2014 shown approximately one-quarter of the way across the axis. A vertical dashed grey line intersects the horizontal axis at the year 2014. The vertical axis is labelled “Number of organisms” and is not marked or scaled.

On each graph, there are three lines, each representing one type of organism. Kelp are represented by a dashed black line; sea stars are represented by a solid black line; and sea urchins are represented by a solid grey line.

Choice A: The kelp line begins on the vertical axis just above the origin. It curves gradually upward until it crosses the 2014 line, then rises steeply upward before levelling off. The sea urchins line begins on the vertical axis high above the kelp line. It curves upward until it peaks at 2014, and then curves gradually downward toward the horizontal axis before levelling off. As it falls downward, it crosses the kelp line. The sea stars line begins on the vertical axis just above the sea urchins line. It remains above and follows the shape of the sea urchins line for the entire length of the curve.

Choice B: The sea urchins line begins on the vertical axis just above the origin. It curves gradually upward until it crosses the 2014 line, then rises steeply upward before levelling off. The sea stars line begins on the vertical axis high above the sea urchins line. It curves upward until it peaks at 2014, and then falls gradually downward toward the horizontal axis before levelling off. As it falls downward, it crosses the sea urchins line. The kelp line begins on the vertical axis just above the sea stars line. It remains above and follows the shape of the sea stars line for the entire length of the curve.

Choice C: The kelp line begins on the vertical axis just above the origin. It extends horizontally until it crosses the 2014 line, where it begins to curve gradually upwards for a short time. The line then rises steeply upward, reaching a peak. The sea stars line begins on the vertical axis just above the kelp line. It follows the kelp line almost exactly, remaining above it. The sea stars line peaks sooner than the kelp line, and then gradually falls, crossing the kelp line. The sea urchins line begins on the vertical axis high above the other two lines. It briefly extends horizontally, and then begins to fall. It falls gradually at first, and then slopes more steeply after it crosses the 2014 line. It crosses the kelp and sea stars lines at the point where those two lines climb most steeply, and then begins to level off before continuing horizontally.

Choice D: The sea stars line begins on the vertical axis just above the origin. It extends horizontally until it crosses the 2014 line, when it begins to curve gradually upward for a short time. The line then rises steeply upward, reaching a peak and then gradually falling. The sea urchins line begins on the vertical axis just above the sea stars line. It follows the sea stars line almost exactly, remaining above it. The sea urchins line levels off just below the peak of the sea stars line. The kelp line begins on the vertical axis high above the other two lines. It briefly extends horizontally, and then begins to fall. It falls gradually at first, and then slopes more steeply after it crosses the 2014 line. It crosses the sea stars and sea urchins lines at the point where those two lines climb most steeply, and then begins to level off before continuing horizontally.

A.

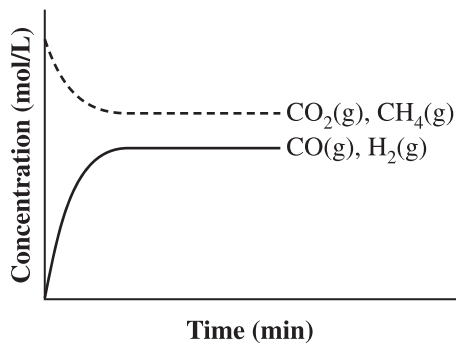

B.

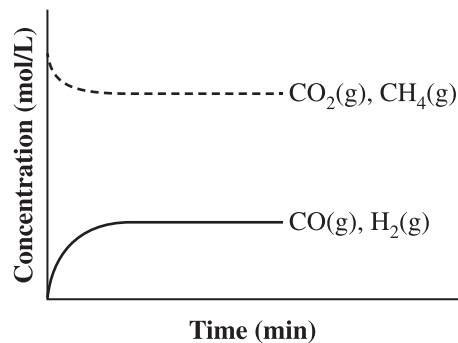

C.

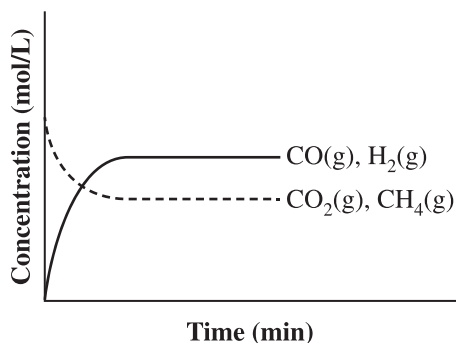

D.

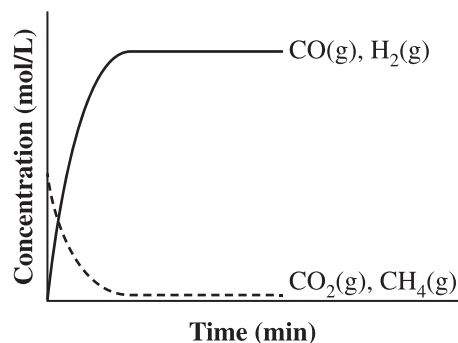

For each choice there is a graph with the horizontal axis labelled “Time” in minutes, and the vertical axis labelled “Concentration” in moles per litre. Neither axis is marked or scaled. There are two curves on each graph, a solid line labelled “C O gas and H two gas,” and a dashed line labelled “C O two gas and C H four gas.”

Choice A: The solid line starts at the origin, rises to the right, and then becomes horizontal approximately halfway up the vertical axis. The dashed line starts near the top of the axis, falls to the right, and then becomes horizontal slightly above the solid line.

Choice B: The solid line starts at the origin, rises to the right, and then becomes horizontal approximately one-quarter of the way up the vertical axis. The dashed line starts near the top of the axis, falls to the right, and then becomes horizontal approximately three-quarters of the way up the axis.

Choice C: The solid line starts at the origin, rises to the right, and then becomes horizontal approximately halfway up the vertical axis. The dashed line starts halfway up the axis, falls to the right, and then becomes horizontal slightly below the solid line.

Choice D: The solid line starts at the origin, rises to the right, and then becomes horizontal near the top of the vertical axis. The dashed line starts halfway up the axis, falls to the right, and then becomes horizontal very close to the horizontal axis.

Bar Graphs

Introduce the graph starting with the title, then describe the label for the horizontal axis, list the label for each bar, and then describe the label and scale for the vertical axis. Describe the height to which each labelled bar rises.

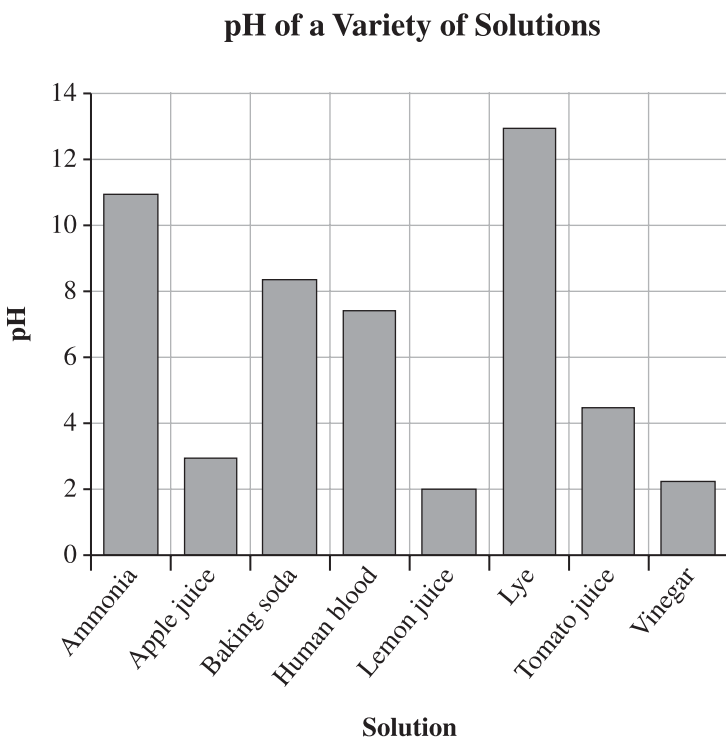

There is a bar graph titled “pH of a Variety of Solutions.” The horizontal axis is labelled “Solution” and from left to right the bars are labelled “Ammonia,” “Apple juice,” “Baking soda,” “Human blood,” “Lemon juice,” “Lye,” “Tomato juice,” and “Vinegar.” The vertical axis is labelled “pH” scaled from zero to fourteen marked and labelled in increments of two.

The bars on the graph read as follows.

Ammonia – pH approximately eleven

Apple juice – pH approximately three

Baking soda – pH approximately eight decimal two

Human blood – pH approximately seven decimal five

Lemon juice – pH exactly two

Lye – pH approximately thirteen

Tomato juice – pH approximately four decimal five

Vinegar – pH approximately two

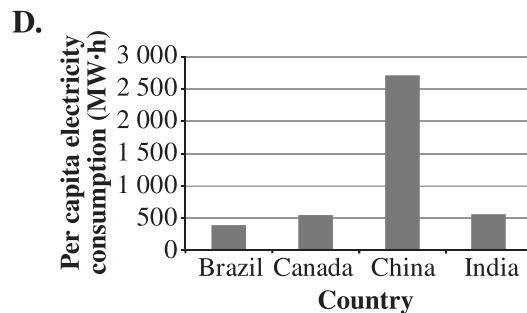
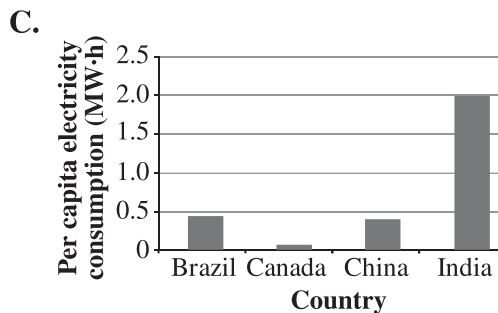
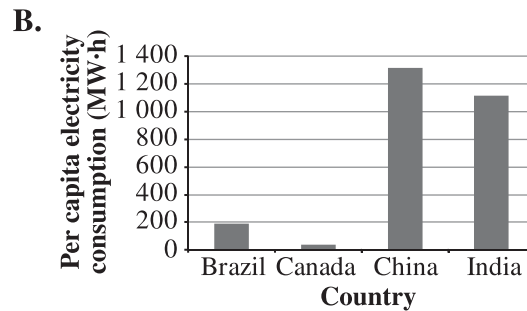
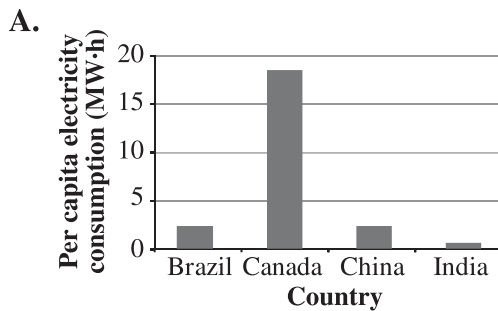

For each choice there is a bar graph with the horizontal axis labelled “Country” with bars for “Brazil,” “Canada,” “China” and “India,” and a vertical axis labelled “Per capita electricity consumption in megawatt-hours.” The vertical axis is scaled and marked differently for each choice. The bars on the graph read as follows:

Choice A: Brazil – approximately two, Canada – approximately eighteen, China – approximately two, India – approximately zero decimal five.

Choice B: Brazil – approximately one hundred ninety, Canada – approximately thirty, China – approximately one thousand three hundred, India – one thousand one hundred.

Choice C: Brazil – approximately zero decimal four five, Canada – approximately zero decimal zero five, China – approximately zero decimal four, India – exactly two decimal zero.

Choice D: Brazil – approximately four hundred, Canada – approximately five hundred and fifty, China – approximately two thousand seven hundred, India – approximately five hundred fifty.

Venn Diagrams

A Venn Diagram Comparing Biofuels and Fossil Fuels

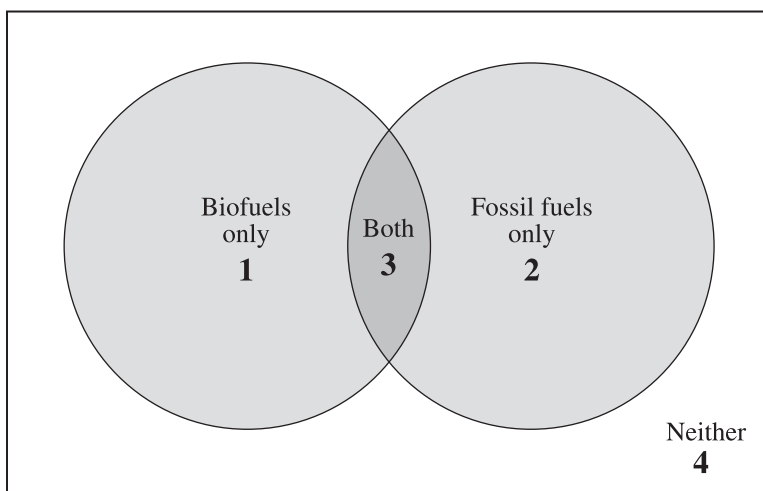

There is a Venn diagram titled “A Venn Diagram Comparing Biofuels and Fossil Fuels.”

The Venn diagram has two circles that overlap. The left part of the left circle is labelled “Biofuels only” and “one.” The right part of the right circle is labelled “Fossil fuels only” and “two.” The area where the circles overlap is labelled “Both” and “three.” The area outside the circles is labelled “Neither” and “four.”

In the Venn diagram below, region 1 represents aspects that are unique to endothermic reactions, region 3 represents aspects that are unique to exothermic reactions, region 2 represents aspects that are shared by both types of reaction, and region 4 represents aspects that are not associated with either type of reaction.

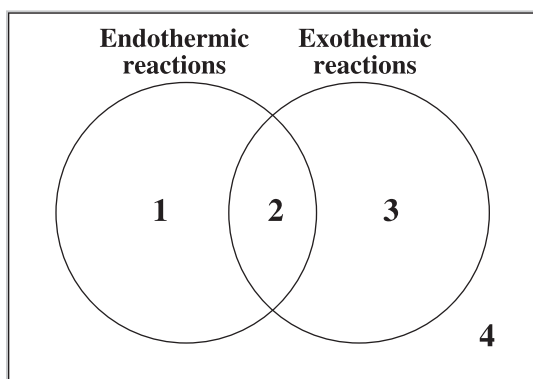

The Venn diagram has two circles that overlap. The circle on the left is labelled “Endothermic reactions” and “one.” The circle on the right is labelled “Exothermic reactions” and “three.” The area where the circles overlap is labelled “two.” The area outside the circles is labelled “four.”

Heart Diagrams

Ventral (Front) Cross-section of a Human Heart

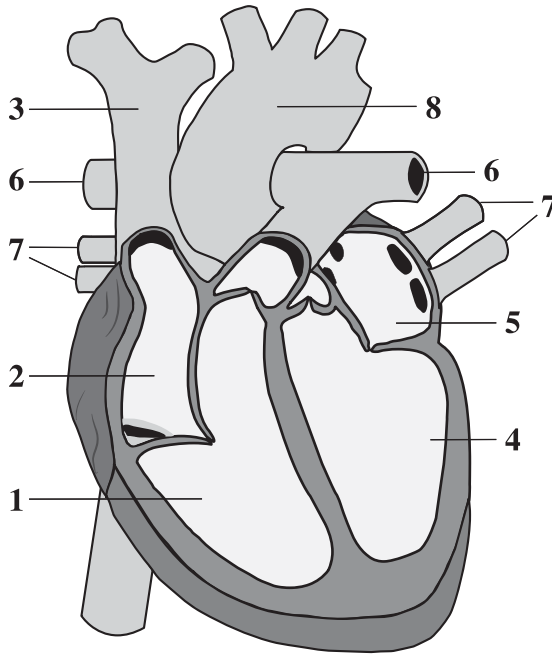

There is a diagram titled “Ventral (Front) Cross-section of a Human Heart,” with eight numbered structures described as follows.

Label one points to a large chamber on the bottom left of the diagram.

Label two points to the small upper chamber on the left of the diagram.

Label three points to a branched blood vessel attached to a small upper chamber on the left side of the diagram. Label four points to a large chamber on the bottom right of the diagram.

Label five points to a small upper chamber on the right of the diagram.

Label six points to a blood vessel that is connected to the large chamber on the bottom left of the diagram and splits into a left and right vessel near the top of the heart.

Label seven points to four small blood vessels that are attached to the small upper chamber labelled 5.

Label eight points to a large, thick blood vessel at the top of the heart that has three smaller branches.

A.

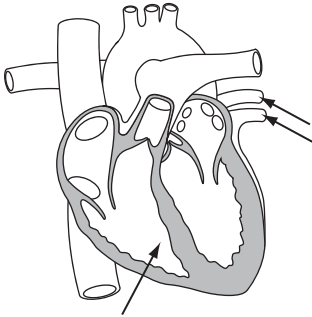

B.

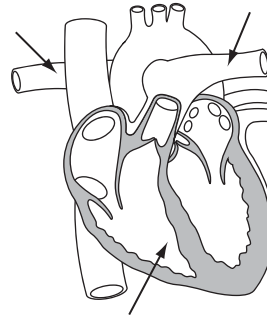

C.

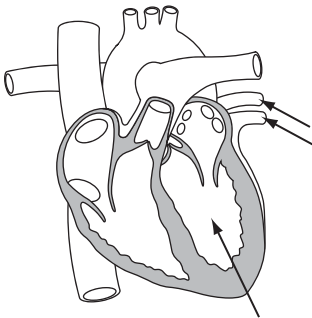

D.

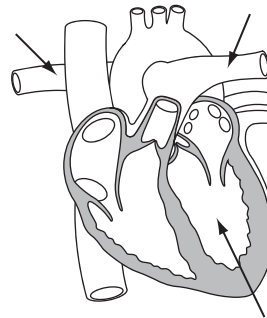

For each choice there is a heart diagram that shows a ventral (or front-view) cross-section of the human heart. Three arrows indicate two structures in each choice.

Choice A. One arrow indicates the left chamber shown at the bottom of the heart diagram and two arrows indicate the blood vessels connected to the top right chamber.

Choice B. One arrow indicates the left chamber shown at the bottom of the heart diagram and two arrows indicate the blood vessels connected to this bottom left chamber.

Choice C. One arrow indicates the right chamber shown at the bottom of the heart diagram and two arrows indicate the blood vessels connected to the top right chamber.

Choice D. One arrow indicates the right chamber shown at the bottom of the heart diagram and two arrows indicate the blood vessels connected to the bottom left chamber.

Gene Symbols

Gene Symbol	Read as
DD	upper case D upper case D
Dd	upper case D lower case d
dd	lower case d lower case d
$B_D_$	upper case B, blank, upper case D, blank
X^HY	X superscript upper case H, Y
X^hY	X superscript lower case h, Y
X^HX^H	X superscript upper case H, X superscript upper case H
X^HX^h	X superscript upper case H, X superscript lower case h
X^hX^h	X superscript lower case h, X superscript lower case h
I^A	upper case I superscript upper case A
I^B	upper case I superscript upper case B
i	lower case i

Pedigrees

Read Roman numerals in pedigrees as Arabic numerals (e.g., Read “I” as “one” and “IV” as “four”).

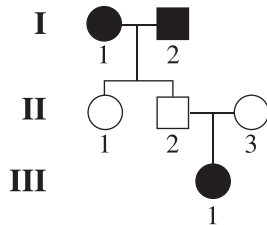

There is a pedigree chart with three generations. Generation one shows a black circle and a black square joined by a horizontal line. Generation two has three individuals. The first two are the offspring of generation one, and they are individuals two-one, a white circle, and two-two, a white square. Individual two-three is a white circle and is joined to individual two-two, the white square, by a horizontal line. Generation three shows their offspring, a black circle.

Many complex multi-generational pedigrees are not scripted; students are directed to use the diagrams in the digital or printed version of their exam booklet.

A.

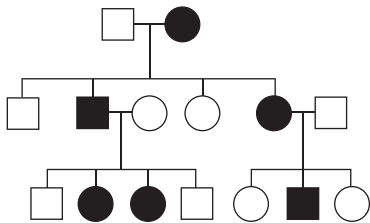

B.

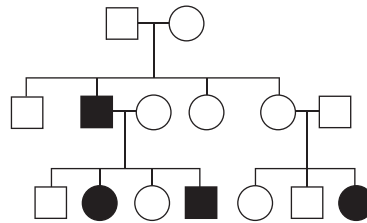

C.

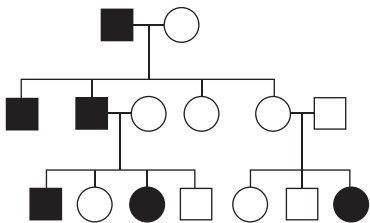

D.

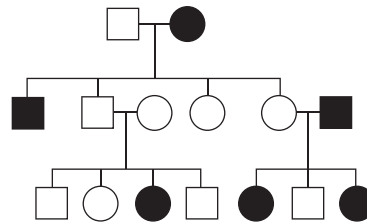

For each choice, there is a diagram of a pedigree. Please refer to the printed or digital version of the examination to answer this multiple-choice question.

Cell Process Diagrams

Two Cellular Processes

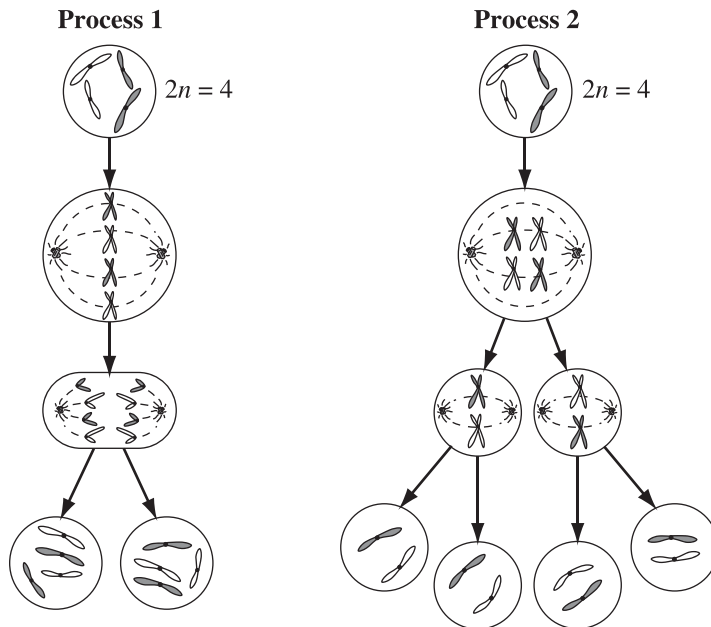

There is a diagram titled “Two Cellular Processes” that shows two processes with several cells arranged vertically and connected by arrows. All of the cells contain chromosomes. Some chromosomes appear as a single, thick line with a dot at the centre, and some appear as an X with a dot at the centre.

Process One begins with a single cell labelled “two n is equal to four” that contains four randomly distributed chromosomes. Each chromosome looks like a single, thick line with a dot at the centre. Two of the chromosomes are shaded and two are not.

An arrow points to a cell that contains four chromosomes arranged vertically in a single line. Each chromosome looks like an X. Several lines extend from the dots in the centre of the chromosomes to star-like structures inside the left and right edges of the cell.

An arrow points to a cell that contains two vertical lines with four chromosomes. The dots of the chromosomes on the left of the cell are pointing slightly toward the left of the cell, their tails pointing towards the centre. The dots of the chromosomes on the right of the cell are pointing slightly towards the right of the cell, their tails pointing toward the centre.

Two arrows point to two single cells, each containing four single chromosomes. In each cell, two chromosomes are shaded and two are not.

Process Two begins with a single cell labelled “two n is equal to four” that contains four single chromosomes, randomly distributed in the cell. Two of the chromosomes are shaded and two are not.

An arrow points to a cell that contains four chromosomes lined up at the centre of the cell, arranged in two vertical lines with two chromosomes in each line. Each chromosome looks like an X. Several lines extend from the dots in the centre of the chromosomes to star-like structures inside the left and right edges of the cell.

Two arrows point to two single cells, each of which contains two chromosomes that look like Xs. Several lines extend from the dots in the centre of the chromosomes to star-like structures inside the left and right edges of the cell.

Two arrows point from each of these two cells to four single cells, each of which contains two single chromosomes randomly distributed. One of the chromosomes is shaded and the other is not.

Neuron Diagrams

Some Components of Nerve-impulse Transmission

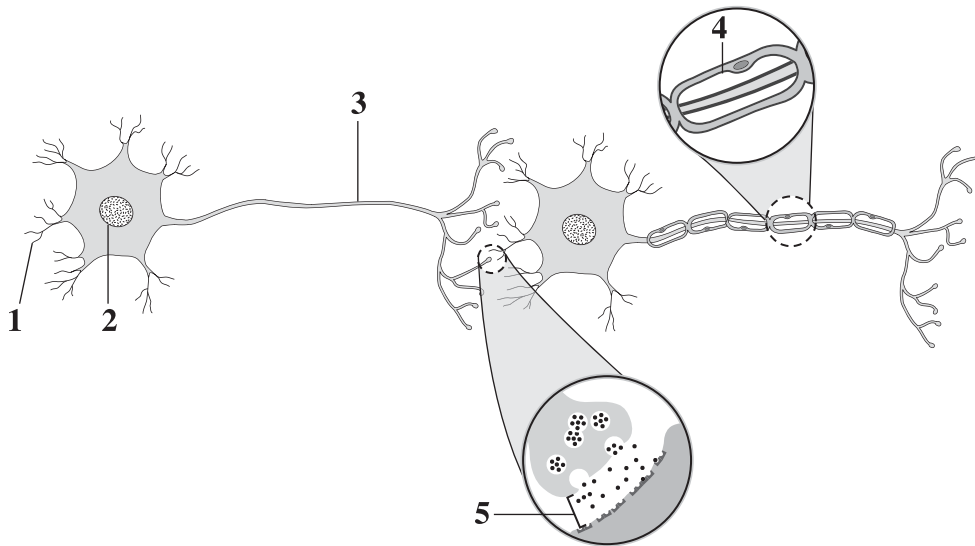

There is a diagram titled “Some Components of Nerve-impulse Transmission” showing two connecting neurons arranged side by side. There are five labelled components.

The first neuron is located on the left of the diagram. Label one points to the dendrites of the first neuron; label two points to the nucleus in the cell body; and label three points to the axon.

The axon has several branches at the ends. There is a small space between the terminal branches of the axon of the first neuron and the dendrites of the second neuron.

The second neuron has the same appearance as the first one, but the axon has a single layer of cells wrapped around it. Label four points to the layer wrapped around the axon.

A magnified view shows details of the area between the two neurons, including a terminal branch, a dendrite, and the space between them. Inside the end of the axon, there are six circles that each contain several small, black molecules. Two of the circles have fused with the edge of the axon and the black molecules are spilling out into the space. The end of the dendrite has several structures embedded in its surface, and some of the small, black molecules have attached to the structures. Label five points to the space between the terminal branch and the dendrite.

Human Brain Diagrams

The Human Brain

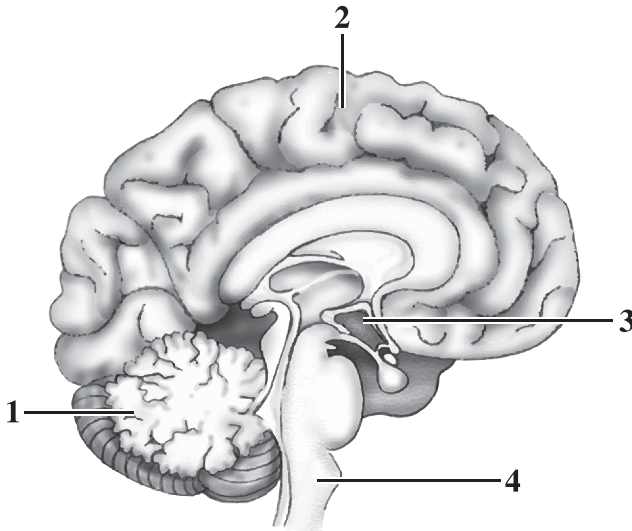

There is a diagram titled “The Human Brain” that shows a side-view cross-section of a brain with four labelled regions. The front of the brain is on the right side of the diagram.

Label one points to a cauliflower-shaped structure at the back of the brain.

Label two points to the top of the brain.

Label three points to an area immediately above a small, round structure attached to the base of the brain by a short stalk.

Between the short stalk and the cauliflower-shaped structure there is a cord-like structure that extends downward. The cord has two bulges in it that extend slightly toward the front of the brain. The top bulge is rounded and the bottom bulge, immediately below, is angular. Label four points to the bottom bulge.

Human Eye Diagrams

The Human Eye

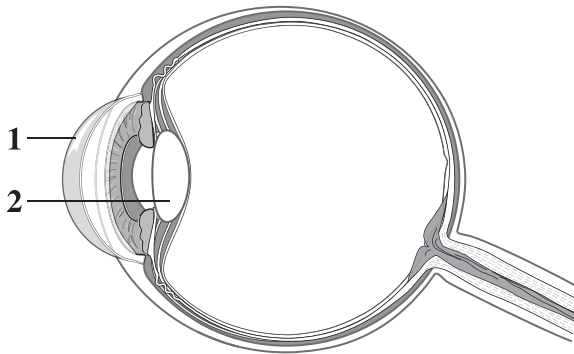

There is a diagram titled “The Human Eye” that shows a side-view of a cross-section of an eye with two labelled structures.

Label one points to the outermost layer at the front of the eye.

Label two points to a biconvex structure located behind the iris.

Human Ear Diagrams

The Human Ear

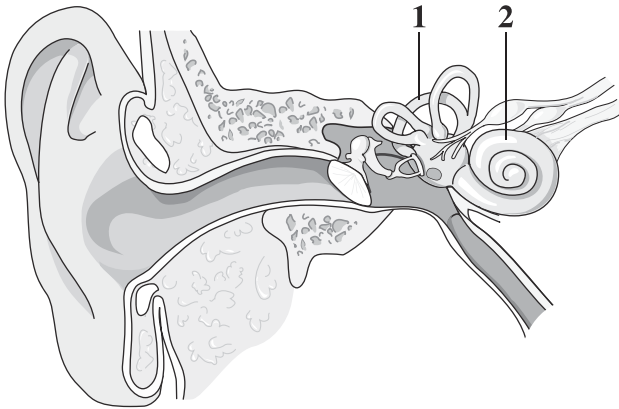

There is a diagram titled “The Human Ear” showing a cross-section of a human ear with two labelled structures. The pinna is on the left of the diagram.

A canal leads from the pinna to a circular membrane separating the canal from the middle ear.

The membrane attaches to the first of three small bones in the middle ear. A canal leads away and downward from the middle ear and the three small bones.

Above the canal and to the right of the three small bones, there are three protruding, arc-like structures. Label one points to one of the arc-like structures.

Next to the three arc-like structures, there is a snail-shaped structure. Label two points to the snail-shaped structure. A nerve leads away from the snail-shaped structure.

Feedback Loop Diagrams

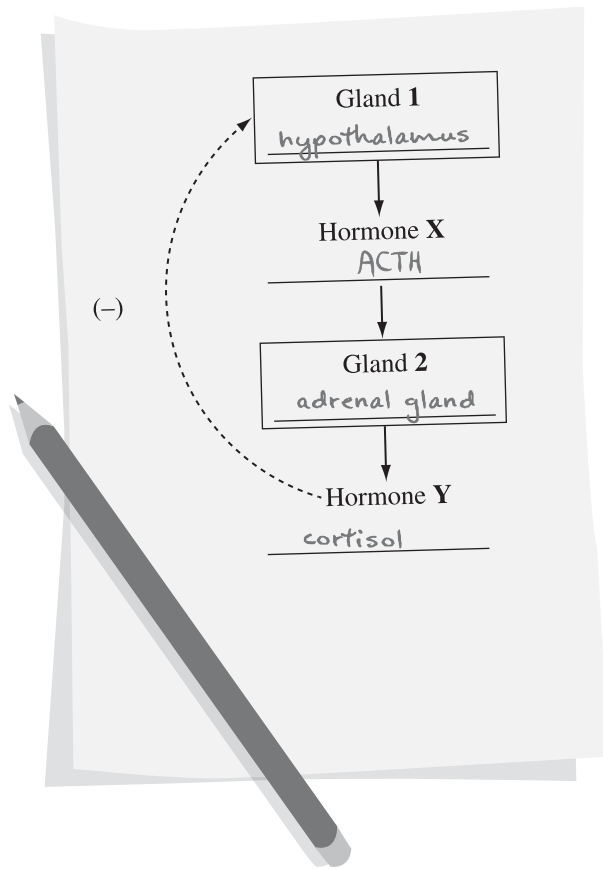

There is a diagram of a worksheet showing some glands and hormones involved in negative feedback. There are some blanks on the worksheet, with a student's writing in the blanks identifying the glands and hormones involved.

At the top of the worksheet, there is a box labelled "Gland one." The student has identified Gland one as "hypothalamus."

There is an arrow extending from Gland one to the label "Hormone X." The student has identified Hormone X as "ACTH."

There is an arrow extending from "Hormone X" to a box labelled "Gland two." The student has identified Gland two as "adrenal gland."

There is an arrow extending from Gland two to the label "Hormone Y." The student has identified Hormone Y as "cortisol."

There is an arrow labelled with a negative sign extending from Hormone Y at the bottom of the worksheet to the box at the top of the worksheet labelled "Gland one."

Endocrine System Diagrams

Some Endocrine Structures

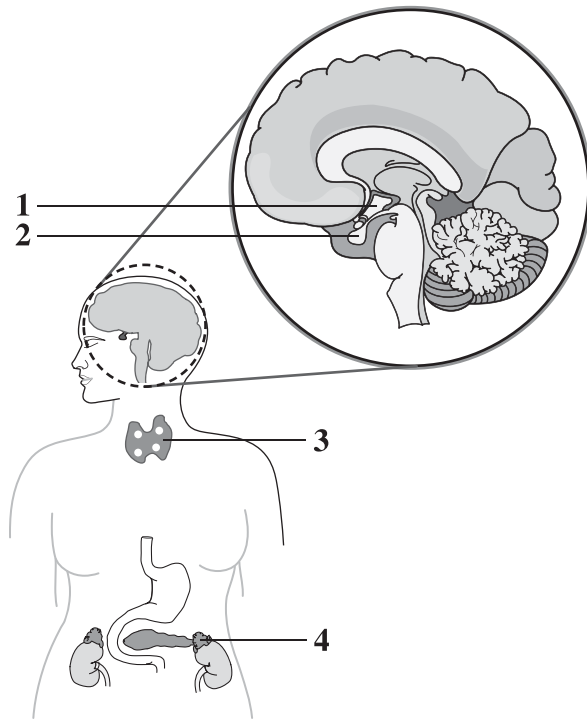

There is a diagram titled “Some Endocrine Structures” that shows an outline of a person with several structures inside. The view of the brain and associated structures is enlarged to show detail. Four glands are labelled.

Label two points to a small, round gland attached to the base of the brain by a short stalk.

Label one points to an area of the brain located immediately above the gland labelled two.

Label three points to a butterfly-shaped gland located in the neck region. This gland has four small, white glands embedded in it that are not labelled.

Label four points to a pyramid-shaped gland located on top of a kidney.

Reproductive System Diagrams

Two Hormonal Pathways in the Human Reproductive System

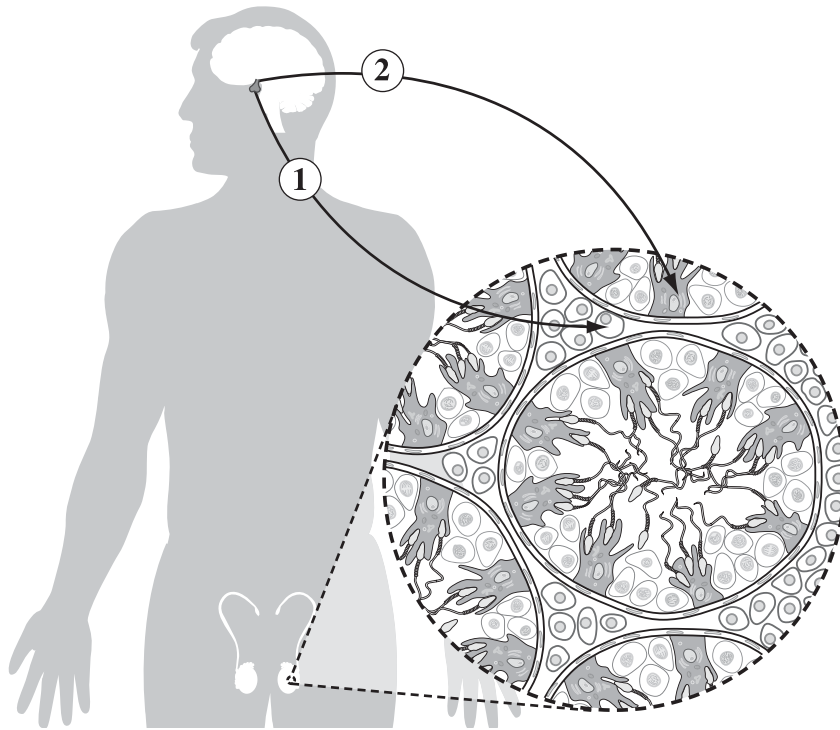

There is a diagram titled “Two Hormonal Pathways in the Human Reproductive System” showing an outline of a person with the brain and testes inside.

A small portion of one of the testes is enlarged. The enlargement is a circular field of view showing a cross-section of a testis as seen through a microscope.

Two labelled arrows extend from a gland at the base of the brain to the cross-section of the testis. The arrows are labelled one and two, and each points to a particular structure in the cross-section.

Inside the field of view, there are one complete circle and four partial circles separated by small cells packed together. Arrow one points to one of the small cells between the circles.

Inside a circle, there are several large, irregularly shaped cells extending from the inner border of the circle toward the centre of the circle. The ends of the cells that extend toward the centre of the circle have finger-like projections. Arrow two points to one of the large, irregular cells with finger-like projections.

The large, irregular cells are surrounded by small cells.

Sperm are wedged in between the finger-like projections of the large, irregular cells.

Human Reproductive Structures

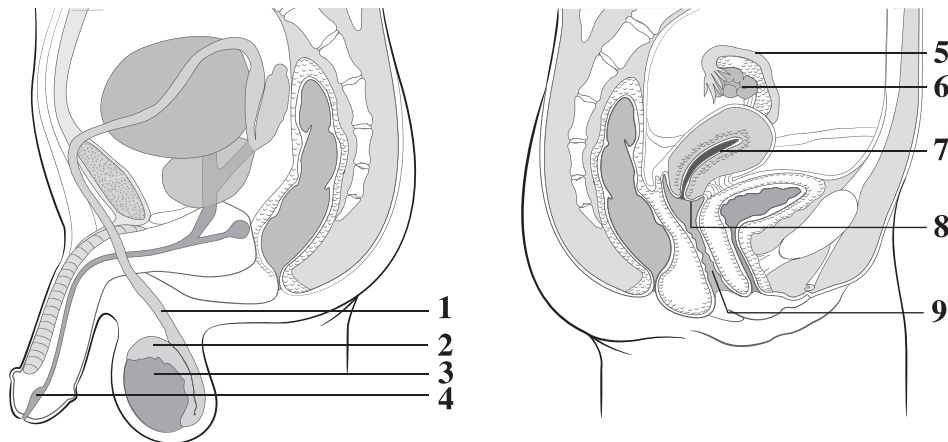

There is a diagram titled “Human Reproductive Structures” that shows a side-view cross-section of reproductive structures, and nine of them are labelled.

The male diagram is on the left and will be described first. At the bottom of the diagram, there is an oval structure inside a pouch-like structure. Label three points to the oval structure.

There is a cap-like structure on top of the oval structure. Label two points to the cap-like structure. A tube, labelled one, extends upward from the cap-like structure and then loops around the bladder.

The tube passes by the seminal vesicle that secretes substances into the tube via a duct, before connecting with another tube that extends downward from the bladder. There are two glands located below the bladder that secrete substances into the tube.

The tube continues away from these two glands until it eventually exits the body. Label four points to the portion of the tube that is located inside the penis.

The female diagram is on the right. Label seven points to a thick-walled, pear-shaped organ that lies almost horizontally in the body. A long tube that ends in finger-like projections leads away from the pear-shaped organ. Label five points to the tube ending in finger-like projections.

Nearby, there is an oval structure that is attached to the pear-shaped organ by a stalk. Label six points to the oval structure.

Label eight points to a cap-like structure that separates the pear-shaped organ from a canal leading to the outside of the body. Label nine points to the canal.

Human Fetus and Associated Structure Diagrams

Some Structures Associated with Fetal Development

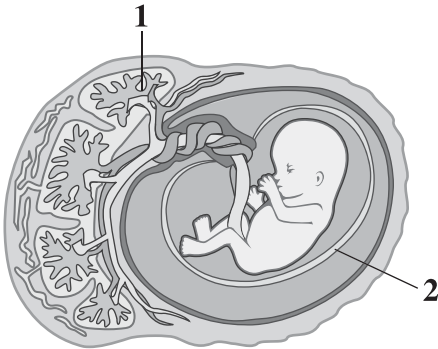

There is a diagram titled “Some Structures Associated with Fetal Development.” The diagram is a cut-away view with the fetus and associated structures inside. Two structures are labelled.

The fetus is shown enclosed in a sac-like structure, both of which are located inside a thick-walled organ. Label two points to the sac-like structure.

A thick tube connects the embryo to a large network of blood vessels embedded in the thick wall of the organ. Label one points to the large network of blood vessels.

Organizational Charts

Some Structures and Processes in Human Development

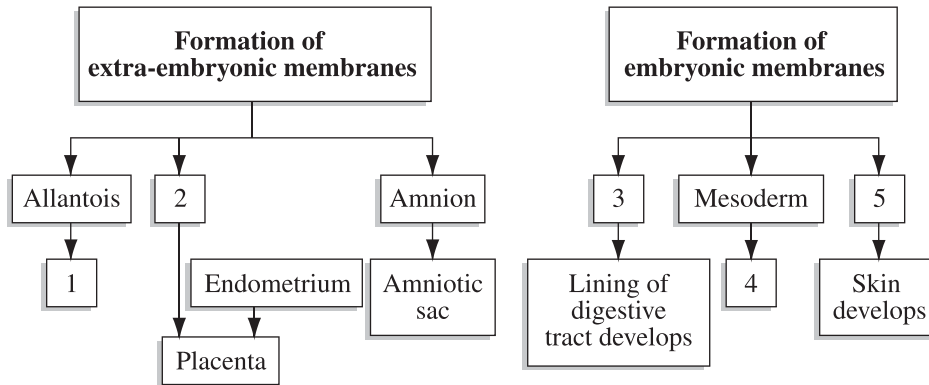

There is a diagram titled “Some Structures and Processes in Human Development” that shows two charts side by side. Each chart has several labelled boxes connected by arrows, and there are five numbered boxes in the diagram.

The first chart is on the left of the diagram. At the top of the chart, there is a box labelled “Formation of extra-embryonic membranes.” An arrow extends from this box to three boxes arranged in a horizontal row below it.

The first box in the row is labelled “Allantois.” An arrow extends from Allantois to a box labelled “one.” The second box in the row is labelled “two,” and an arrow extends from it to a box labelled “Placenta.” There is another box labelled “Endometrium” that also has an arrow extending to the box labelled “Placenta.” The third box in the row is labelled “Amnion,” and an arrow extends from it to a box labelled “Amniotic sac.”

The second chart is on the right of the diagram. At the top of the chart, there is a box labelled “Formation of embryonic membranes.” An arrow extends from this box to three boxes arranged in a horizontal row below it.

The first box in the row is labelled “three.” An arrow extends from box three to a box labelled “Lining of digestive tract develops.” The second box in the row is labelled “Mesoderm,” and an arrow extends from it to a box labelled “four.” The third box in the row is labelled “five,” and an arrow extends from it to a box labelled “Skin develops.”

Micrographs



There is a micrograph showing several cells in an onion root tip at various stages of mitosis.

One of the cells is labelled “one,” and it shows several long, slender structures collected into a single point at one pole of a particular cell; and several long, slender structures collected into a single point at the other pole of the same cell. There are no visible structures at the centre of the cell.

Scanning Electron Microscope (SEM) Image of Blood Components

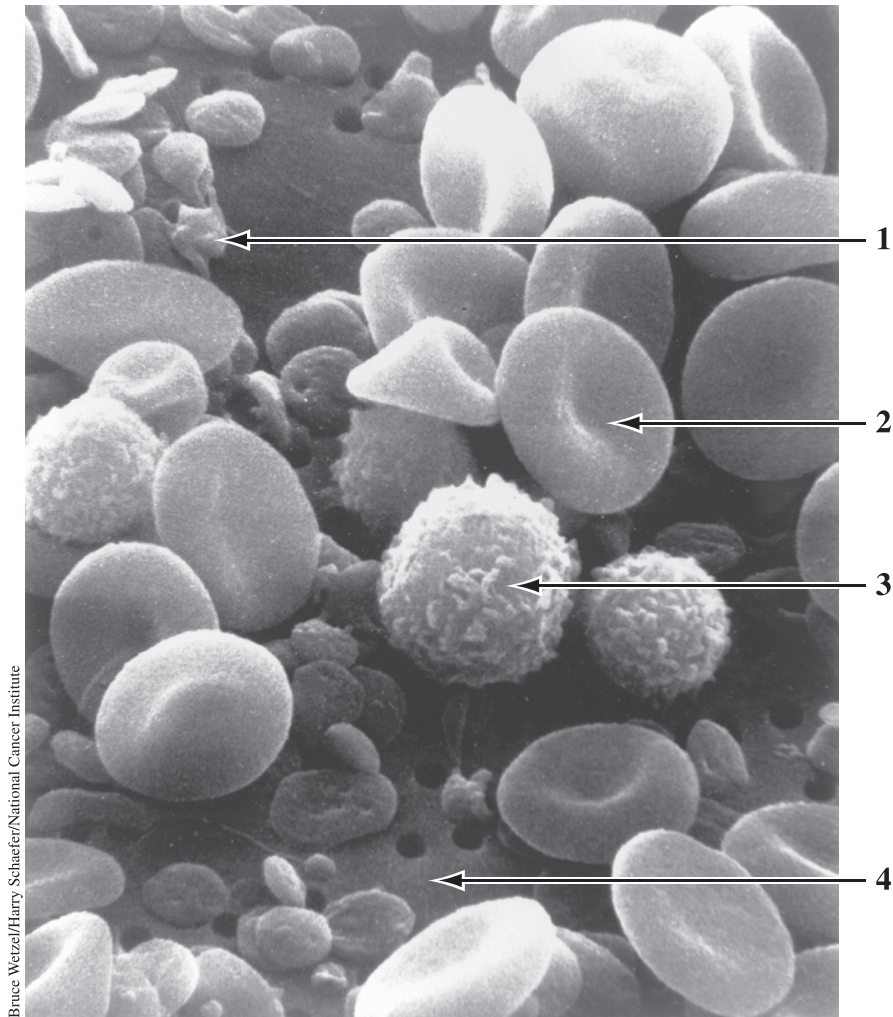

A micrograph titled “Scanning Electron Microscope (SEM) Image of Blood Components” is shown courtesy of the Bruce Wetzel/Harry Schaefer/National Cancer Institute. The micrograph shows dozens of small, irregularly shaped components labelled “one.” There are approximately thirty smooth biconcave discs labelled “two,” and four large, circular objects with a rough surface labelled “three.” Label “four” points to the empty space between other blood components.

Karyotype Diagrams

A Human Karyotype

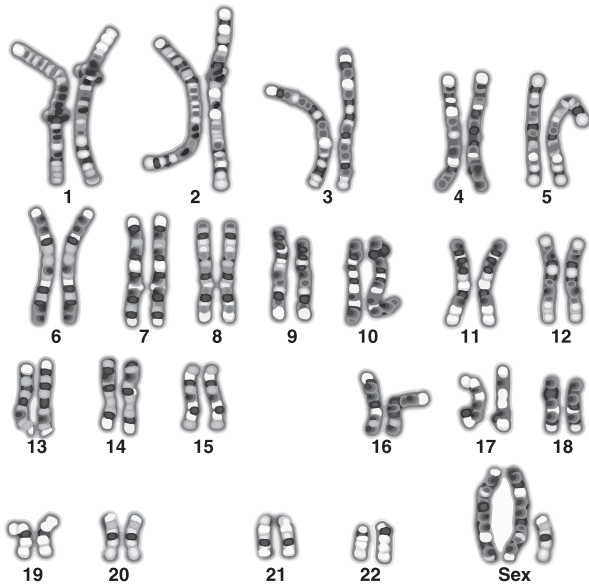

There is a diagram titled “A Human Karyotype” that shows a photograph of four rows of chromosomes arranged in pairs. The two chromosomes in each pair are similar in length and composition, and each pair has a number below it. The numbers are arranged from one to twenty-two.

The first row of chromosomes shows five pairs of chromosomes, each pair numbered one through five.

The second row of chromosomes shows seven pairs of chromosomes, numbered six through twelve.

The third row of chromosomes shows six pairs of chromosomes, numbered thirteen through eighteen.

The fourth row of chromosomes shows four pairs of chromosomes numbered nineteen through twenty-two, and then two long chromosomes and one short chromosome together labelled “Sex.”

Life Cycle Diagrams

Two Life Cycles of *S. cerevisiae*

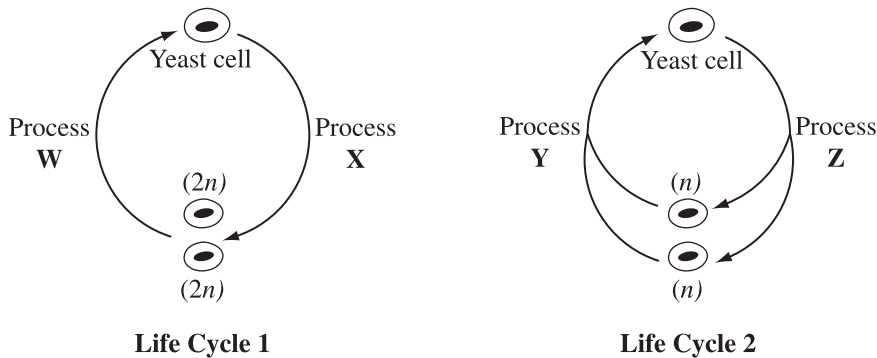

There is a diagram titled “Two Life Cycles of *S. cerevisiae*” that consists of two smaller diagrams, subtitled “Life Cycle One” and “Life Cycle Two.”

The first small diagram, Life Cycle One, shows a cell at the top of the diagram labelled “Yeast cell.” An arrow labelled “Process X” extends to the right and downward to two more cells at the bottom, each labelled “Two n.” An arrow labelled “Process W” extends to the left and upward from these cells until it reaches the yeast cell at the top of the life cycle.

The second small diagram, Life Cycle Two, shows a cell at the top of the diagram labelled “Yeast cell.” An arrow labelled “Process Z” extends to the right and downward for a short distance and then splits into two arrows. The first arrow points to a cell at the bottom of the life cycle that is labelled “n.” The second arrow points to a second cell at the bottom of the life cycle that is also labelled “n.” An arrow labelled “Process Y” extends to the left and upward from each of the two cells at the bottom of Life Cycle Two and the arrows join to form a single arrow. The single arrow continues upward until it reaches the yeast cell at the top of the life cycle.

Life Cycle of *Equisetum*

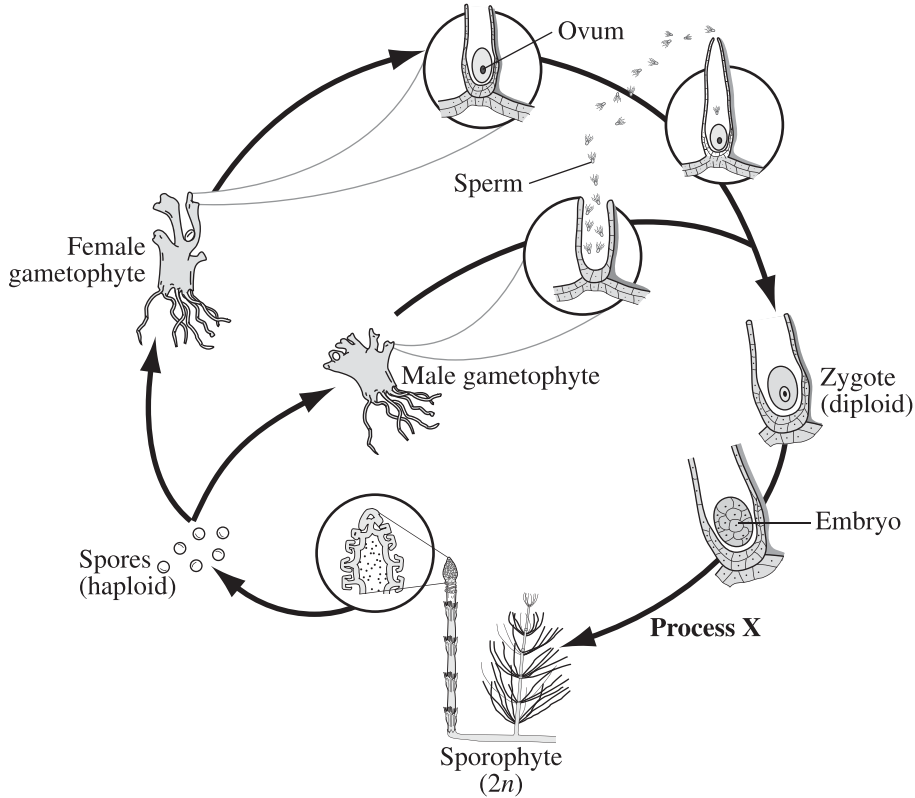

There is a diagram titled “Life Cycle of *Equisetum*” that shows several structures arranged in a circle and connected by arrows.

The life cycle will be described in a clockwise direction. Beginning at the upper left, there are two plants side-by-side: one is labelled “Female gametophyte,” and the other is labelled “Male gametophyte.” An arrow leads away from the female gametophyte to an enlarged view of part of the plant, showing a single cell labelled “ovum” enclosed in a multicellular structure. A second arrow leads away from the male gametophyte to an enlarged view of part of the plant, showing small cells labelled “sperm” emerging from a multicellular part of the male plant. Some of the sperm are shown approaching the ovum housed in the female gametophyte.

The two arrows join to form a single arrow, which points to a single cell labelled “Zygote” and “diploid.” The arrow continues to the next structure, which is a multicellular structure labelled “Embryo.”

An arrow labelled “Process X” extends away from the embryo to a structure labelled “Sporophyte” and “Two n.” Part of the sporophyte is enlarged to show that spores are produced and released from there. An arrow extends away from the enlargement to a few single-celled structures labelled “Spores” and “haploid.”

One arrow extends away from the spores to the female gametophyte plant near the top of the life cycle, and a second arrow extends away from the spores to the male gametophyte plant near the upper left of the life cycle.

DNA Diagrams

A Cell Process

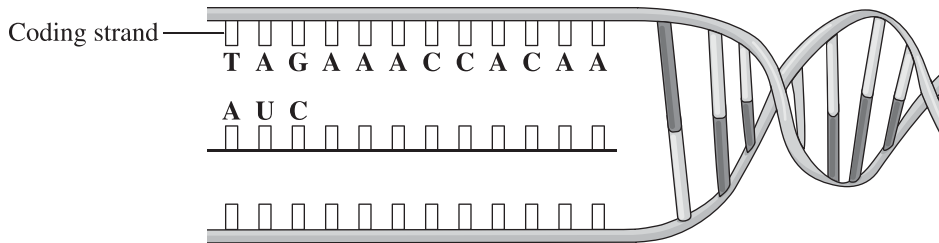

There is a diagram titled “A Cell Process” that shows a twisted, ladder-like structure extending horizontally. The left-hand portion of the ladder is shown untwisted and separated into top and bottom sections. Both sections have portions of the rungs of the ladder attached and facing the centre of the molecule, where the rungs would normally be bonded together.

The top section is labelled “Coding strand” and each of the rungs is labelled with a single capital letter, which together make the following sequence, read from left to right: TAG AAA CCA CAA.

Between the top and bottom sections of the untwisted ladder, there is a molecule drawn as a single line with smaller blocks facing the coding strand. Each of the first three blocks is labelled with a single capital letter. When read from left to right, the three-letter sequence is AUC.

Chemical Reaction Equations

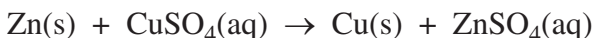

Z N solid, plus, C U S O four aqueous, produces, C U solid, plus, Z N S O four aqueous



Eight S O two gas, plus, thirty-two H positive aqueous, plus, thirty-two e negative, produces, S eight gas, plus, sixteen H two O gas

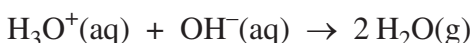

H three O positive aqueous, plus, O H negative aqueous, produces, two H two O gas

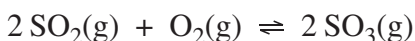

Two S O two gas, plus, O two gas, is in equilibrium with, two S O three gas



Open bracket N H two closed bracket two C O solid, plus, seven over two O two gas, produces, C O two gas, plus, two H two O liquid, plus, two N O two gas



C H four gas, plus, H two O gas, plus, energy in the presence of a catalyst is in equilibrium with, C O gas, plus, three H two gas

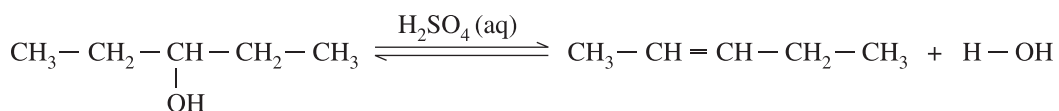

The reactant in the equation, reading from left to right, is represented by a C H three group single bonded to a C H two group single bonded to a C H group single bonded to a C H two group single bonded to a C H three group. Also attached to the C H group is an O H group. In the presence of H two S O four aqueous, the reactant is in equilibrium with one product represented by a C H three group single bonded to a C H group, double bonded to a C H group, single bonded to a C H two group, single bonded to a C H three group, plus a second product represented by an H single bonded to an O H group.

Equilibrium Law Expressions

$$K_c = \frac{[\text{SO}_3(\text{g})]}{[\text{SO}_2(\text{g})]^2[\text{O}_2(\text{g})]}$$

K_c is equal to the molar concentration of S O three gas divided by the product of the molar concentration of S O two gas raised to the power of two and the molar concentration of O two gas

Enthalpy Notation

ΔH

Delta H

ΔH°

Delta H standard

$\sum \Delta_f H^\circ$

Sum of delta, subscript f, H standard

$\Delta_r H$

Delta subscript r H

$\Delta_r H^\circ = \sum n \Delta_f H^\circ \text{products} - \sum n \Delta_f H^\circ \text{reactants}$

Delta subscript r, H standard, is equal to, the sum of n delta subscript f H standard products, minus, the sum of n delta subscript f H standard reactants

Redox Notation

E°_{net}

E standard net

The oxidation number of chlorine in $\text{OCl}^-(\text{aq})$ is +/- _____ (Record in the **first** column)

The oxidation number of chlorine in O C L negative aqueous is positive or negative blank.
Record in the first column.

Molecular Structures



H N open bracket C H two C H two O H closed bracket two aqueous and H two N open bracket C H two C H two O H closed bracket subscript two superscript positive aqueous

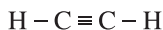

A carbon is single bonded to a hydrogen and triple bonded to another carbon. The second carbon is single bonded to a hydrogen.

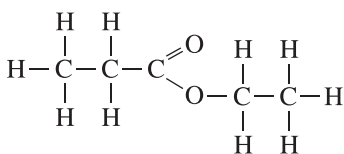

The compound, described from left to right, is a C is single bonded to three Hs and single bonded to a second C. The second C is single bonded to two Hs and single bonded to a third C. The third C is double bonded to an O and single bonded to a second O. The second O is single bonded to a fourth C. The fourth C is single bonded to two Hs and a fifth C. The fifth C is single bonded to three Hs.

Coumarin

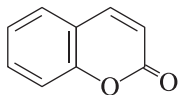

There is a line diagram titled “Coumarin.” The line diagram consists of a six-sided ring structure containing three double bonds within the ring on every other side. Attached to this structure is a second six-sided ring structure containing two double bonds within the ring. One double bond is shared with the first ring structure and the other double bond is on the top right. At the bottom of the second ring structure is an O single bonded between two of the lines. Attached to the bottom right side of the second ring structure is a double-bonded O.

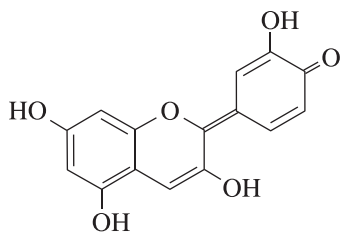

There is a line diagram that consists of a six-sided ring structure containing three double bonds within the ring on every other side. Attached to this structure are two O H groups, one single bonded on the top left and one single bonded on the bottom. Also, attached to the right side of this structure is a second six-sided ring structure. On the bottom right of this structure, there is a double bond and a single-bonded O H group attached. At the top of this ring structure, there is an O single bonded between two of the lines. Also, attached to the top right of this structure is a double bond that attaches to a third six-sided ring structure. This third ring structure has two double bonds within the ring, one on the top left and one on the bottom right. Attached to the top of this ring structure is a single-bonded O H group and attached to the top right of the ring structure is a double-bonded O.

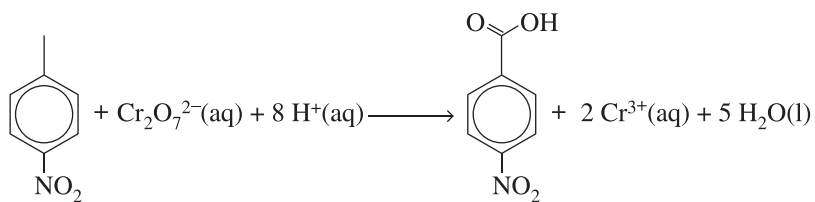

4-nitrotoluene

4-nitrobenzoic acid

The first reactant in the equation is a line diagram that consists of a six-sided structure containing a ring inside. Attached to the top of the structure is a vertical line going up. Attached to the bottom of the structure is a single-bonded N O two group. This structure is labelled "four-nitrotoluene." The second reactant is C R two O subscript seven superscript two negative aqueous. The third reactant is eight H positive aqueous. This produces the first product, which is a line diagram that consists of a six-sided structure containing a ring inside. Attached to the top of the structure is a vertical line going up. At the end of the vertical line is a double-bonded O and a single bonded O H group. Attached to the bottom of the structure is a single bonded N O two group. This structure is labelled "four-nitrobenzoic acid." The second product is two C R three positive aqueous, plus the third product, five H two O liquid.

Electrochemical Cell Diagrams

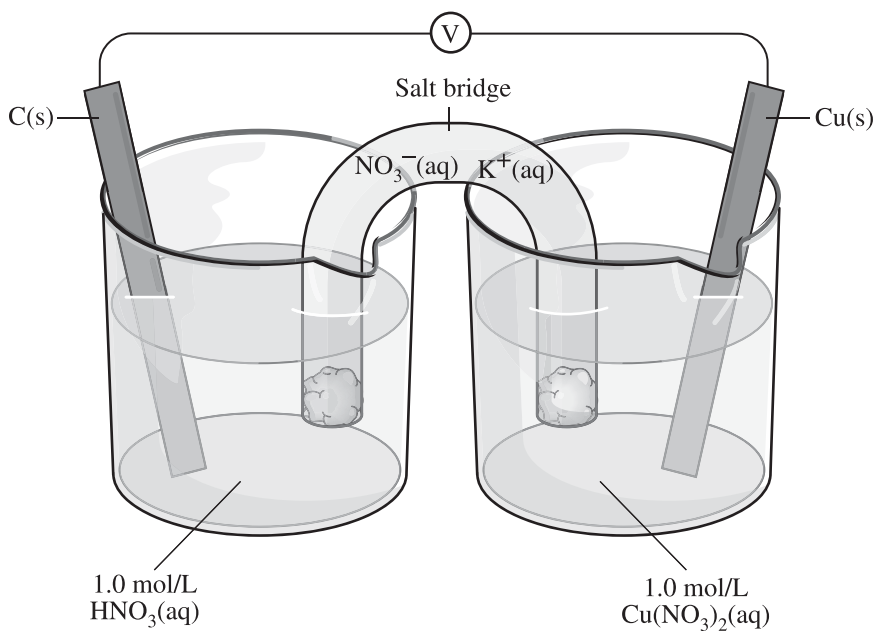

There is a diagram of an electrochemical cell that shows two beakers connected with a U-tube, labelled “Salt bridge,” which has plugs at each end. The U-tube contains a solution labelled “N O subscript three superscript negative aqueous and K positive aqueous.” The beaker on the left contains a solution labelled “one decimal zero moles per litre H N O three aqueous” and a vertical rod labelled “C solid.” The beaker on the right contains a solution labelled “one decimal zero moles per litre C U open bracket N O three closed bracket two aqueous.” This beaker also contains a vertical rod labelled “C U solid.” The two vertical rods are connected with a wire that passes through a circle labelled “V.”

Fractional Distillation Tower Diagrams

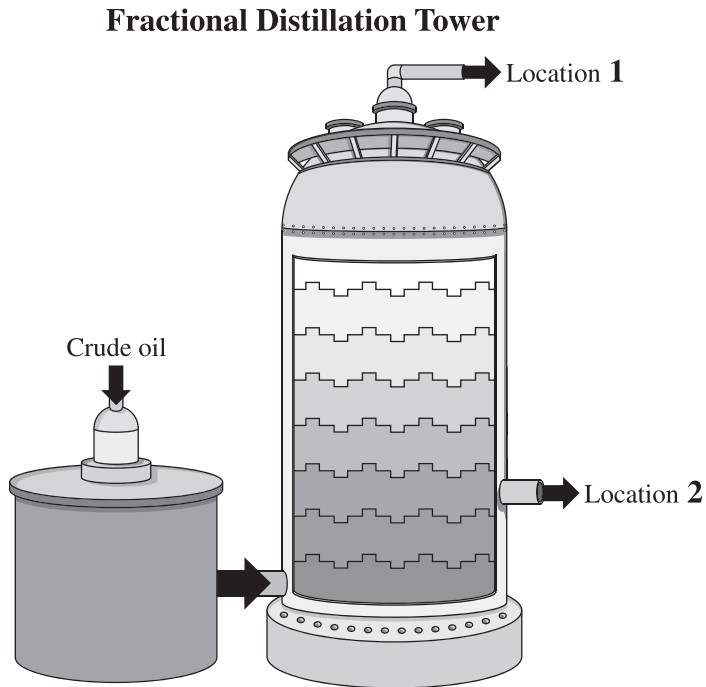

There is a diagram titled “Fractional Distillation Tower.” There are two cylinders: a short cylinder on the left and a taller cylinder on the right showing a cut-away view. On the top of the cylinder on the left, an arrow points to a pipe and is labelled “Crude oil.” There is a pipe with an arrow leading from the middle of the cylinder on the left to the bottom of the cylinder on the right. The cylinder on the right is divided into eight shaded sections. At the top of this cylinder is an outlet pipe labelled “Location one.” Just below the middle of this cylinder is a second outlet pipe labelled “Location two.”





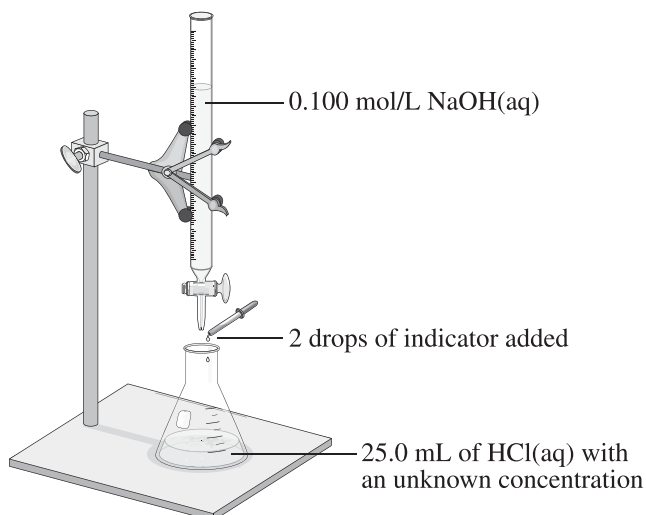

Titration Apparatus Diagrams



Illustration of a Titration Setup



A diagram titled “Illustration of a Titration Setup” shows a support stand with a burette clamp holding a burette. An Erlenmeyer flask rests upon the base of the support stand under the tip of the burette. The liquid in the burette is labelled “zero decimal one zero zero moles per litre N A O H aqueous.” A dropper above the mouth of the Erlenmeyer flask is labelled “two drops of indicator added.” The liquid in the bottom of the Erlenmeyer flask is labelled “twenty-five decimal zero millilitres of H C L aqueous with an unknown concentration.”

WHMIS Pictograms

WHMIS Pictogram	Name	Read as
	Gas Cylinder	A diamond containing a gas cylinder
	Flame	A diamond containing flames
	Flame over Circle	A diamond containing a burning letter O
	Corrosion	A diamond containing a test tube spilling a substance onto a surface and a test tube spilling a substance onto a human hand. Where the substance touches the surface and the hand, holes are forming and heat waves are shown.
	Skull and Crossbones	A diamond containing a skull and crossbones
	Health Hazard	A diamond containing the head and upper body of a person with a hole in the centre of the chest. The hole radiates outward in several directions.

WHMIS Pictogram	Name	Read as
	Biohazardous Infectious Materials	A circle containing a biohazard symbol
	Exploding Bomb	A diamond containing an exploding bomb
	Exclamation Mark	A diamond containing an exclamation mark

Nuclear Equations

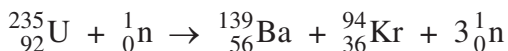

Superscript two-hundred thirty-five subscript ninety-two U, plus, superscript one subscript zero n, produces, superscript one-hundred thirty-nine subscript fifty-six B A, plus, superscript ninety-four subscript thirty-six K R, plus, three, superscript one subscript zero n.

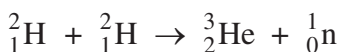

Superscript two subscript one H, plus, superscript two subscript one H, produces, superscript three subscript two H E, plus, superscript one subscript zero n.

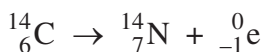

Superscript fourteen subscript six C, produces, superscript fourteen subscript seven N, plus, superscript zero subscript negative one e.

Isotopes

U-235 or Uranium-235

Uranium two thirty-five or uranium two hundred thirty-five

Po-210 or Polonium-210

Polonium two ten or polonium two hundred ten

Field Line Diagrams

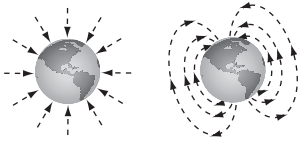

Two diagrams of Earth are shown with dashed arrows representing the direction of field lines.

In the first diagram, the field lines are shown pointing inward from evenly spaced points around the circumference of Earth.

In the second diagram, the field lines are shown as three ovals, one inside the other, originating from within Earth. Arrows on the ovals point from the geographical south pole to the geographical north pole.

Circuit Diagrams

If the purpose of the question is to interpret the diagram in order to perform a calculation or identify the correct configuration of components, then the components should be identified (e.g., resistor, ammeter, voltmeter, etc.). If the purpose of the question is to identify the name or the role of the components shown, then the representation of the components should be described (e.g., a zig-zag line, a circle containing an uppercase letter A, etc.).

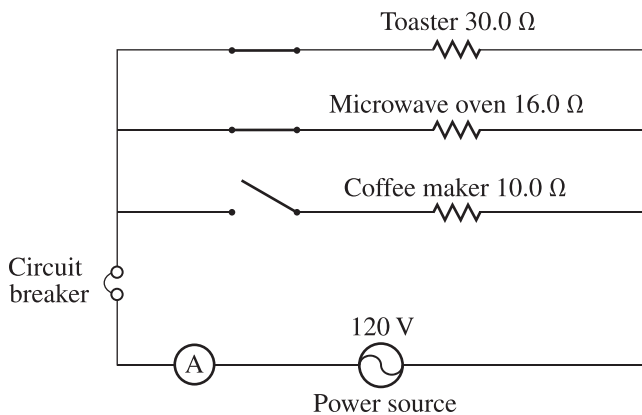

There is a rectangular circuit shown with four horizontal wires and two vertical wires. Each of the top three wires has a switch on the left side and a resistor on the right side. The horizontal wires will be described from top to bottom as follows. On the top wire, the switch is closed and the resistor is labelled "Toaster, thirty decimal zero ohms." On the second wire, the switch is closed and the resistor is labelled "Microwave oven, sixteen decimal zero ohms." On the third wire the switch is open and the resistor is labelled "Coffee maker, ten decimal zero ohms." The bottom wire shows an ammeter on the left and a power source labelled "Power source, one hundred twenty volts" in the middle of the wire. The vertical wire on the left side contains a labelled "Circuit breaker" located between the third and bottom horizontal wires. There are no components on the vertical wire on the right side.

A Circuit Diagram

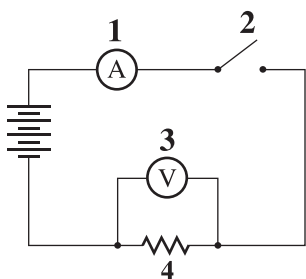

There is a diagram titled “A Circuit Diagram” that includes four numbered symbols. The rectangular circuit contains a battery with four cells on the left side and a vertical wire on the right. The four numbered symbols are shown on either the top or the bottom of the circuit and are described as follows: Symbol one is a circle containing an uppercase letter A and it is shown on the left side of the top wire. Symbol two consists of two dots separated by a space. The left dot is attached to an upward right diagonal line that is the same length as the space between the dots. Symbol three is a circle containing an uppercase letter V with a wire extending out either side of the circle and it is shown above the bottom wire. These wires attach to the bottom wire of the circuit on either side of symbol number four. Symbol four is a zigzag line shown in the middle of the bottom wire.

A student constructed a circuit containing an ammeter, a voltmeter, an LED light, and a small panel of photovoltaic cells.

Some Symbols for Components in a Circuit Diagram

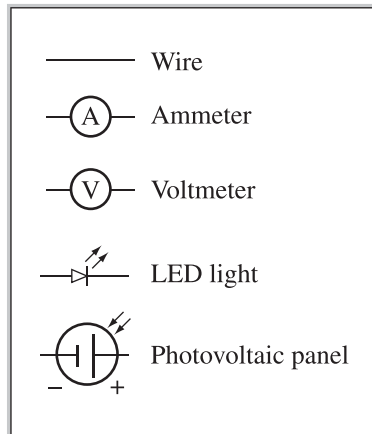

Which of the following diagrams shows an ammeter and a voltmeter correctly arranged in the circuit?

A.

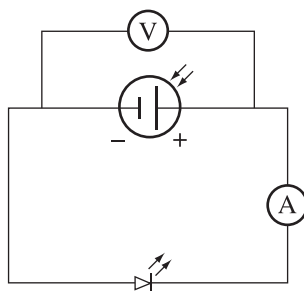

B.

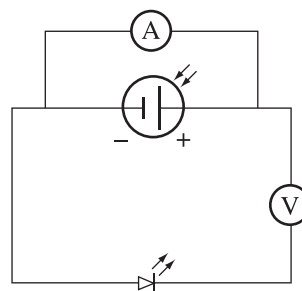

C.

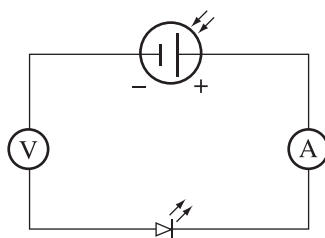

D.

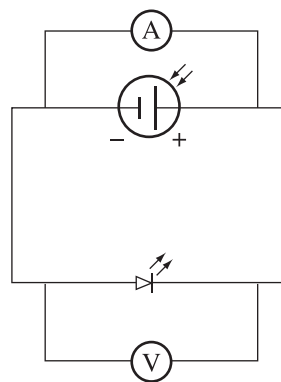

There is a legend titled “Some Symbols for Components in a Circuit Diagram” with five labelled symbols:

“Wire” is represented by a straight horizontal line.

“Ammeter” is represented by a straight horizontal line with a circle containing an upper case letter A.

“Voltmeter” is represented by a straight horizontal line with a circle containing an upper case letter V.

“LED light” is represented by a horizontal right-facing arrow pointing toward a short vertical line from which a wire extends from its center to the right. Two short arrows point upward to the right from just above the short vertical line.

“Photovoltaic panel” is represented by a circle containing a horizontal wire on the left ending at the center of a short vertical line, a small space, a longer vertical line, with a wire extending from its center to the right. Just outside the circle are two diagonal inward facing arrows pointing from the upper right, a negative sign at the bottom left, and a positive sign at the bottom right.

Which of the following diagrams shows an ammeter and a voltmeter correctly arranged in the circuit?

For each choice there is a circuit diagram that contains a photovoltaic panel at the top and an LED light at the bottom.

Choice A. The voltmeter is connected to a second wire connected to the circuit and is located above the photovoltaic panel. On the right side of the circuit is an ammeter.

Choice B. The ammeter is connected to a second wire connected to the circuit and is located above the photovoltaic panel. On the right side of the circuit is a voltmeter.

Choice C. The ammeter is on the right side of the circuit and the voltmeter is on the left side of the circuit.

Choice D. The ammeter is connected to a second wire connected to the circuit and is located above the photovoltaic panel. The voltmeter is connected to a third wire connected to the circuit and is located below the LED light.

Transformer Diagrams

Diagram Representing an Ideal Transformer

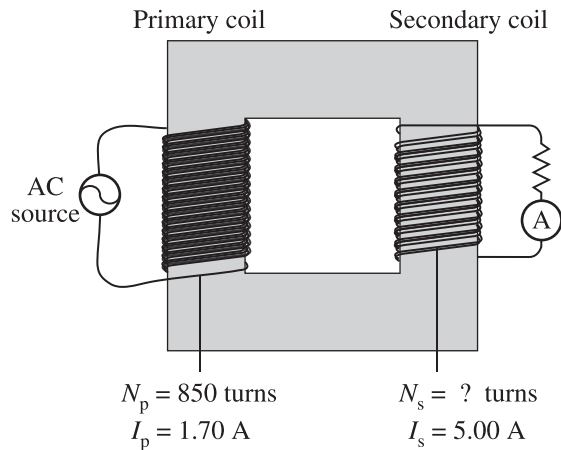

There is a diagram titled “Diagram Representing an Ideal Transformer” that shows a square frame in the center of the diagram.

A wire is coiled numerous times around the left side of the frame and is labelled “Primary coil.” The primary coil is also labelled “ N subscript p is equal to eight hundred fifty turns,” and “ I subscript p is equal to one decimal seven zero amperes.” Each end of this wire of the primary coil is attached to a power source labelled “AC source.”

A wire is coiled several times around the right side of the frame and is labelled “Secondary coil.” The secondary coil is also labelled “ N subscript s is equal to question mark turns” and “ I subscript s is equal to five decimal zero zero amperes.” The wire of this secondary coil is attached to an ammeter and a resistor.

Motor Diagrams

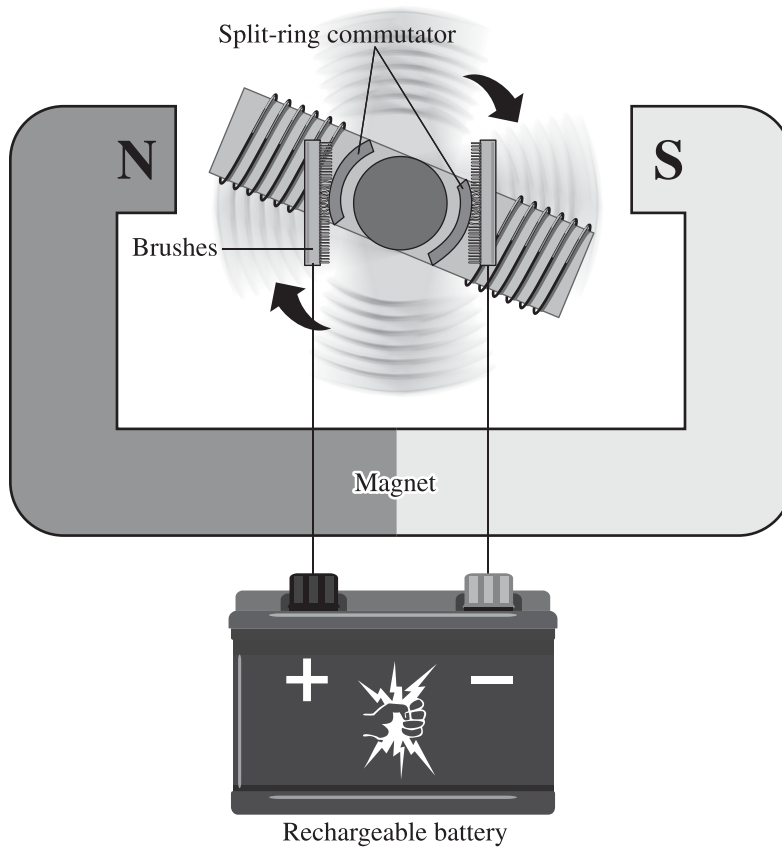

There is a diagram of an electric motor. An armature with a coil of wire is positioned between two poles of a U-shaped magnet labelled “Magnet.” Circular arrows beside the armature indicate that the armature is spinning in a clockwise direction. The magnet pole on the left is labelled “N” and the magnet pole on the right is labelled “S.” A labelled “Split-ring commutator” is attached to the middle of the armature and the split-ring commutator is in contact with labelled “Brushes” on both sides of the split-ring commutator. There is a labelled “Rechargable battery” below the magnet. The brush on the left is attached by a wire to the positive terminal of the battery and the brush on the right is attached by a wire to the negative terminal of the battery.

Spectra Diagrams

Reference Spectra of Various Elements and Spectrum of a Distant Star

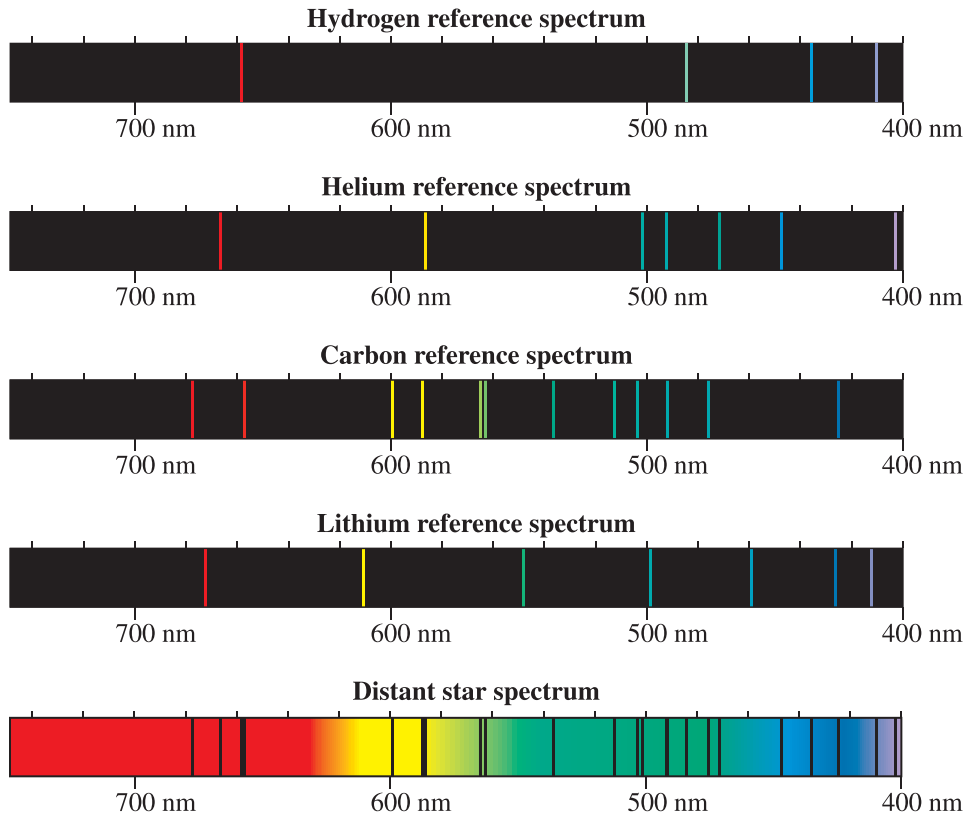

There is a diagram titled “Reference Spectra of Various Elements and Spectrum of a Distant Star.” Five horizontal spectra are shown. Each spectrum is scaled from seven hundred forty nanometres to four hundred nanometres, marked in increments of twenty nanometres, and labelled in increments of one hundred nanometres. The bottom diagram is a full-coloured spectrum titled “Distant Star Spectrum.” There are twenty vertical black lines shown crossing this spectrum.

The other four spectra diagrams are reference spectra titled “Hydrogen reference spectrum,” “Helium reference spectrum,” “Carbon reference spectrum,” and “Lithium reference spectrum.” Each of these spectra is black in colour with vertical coloured lines crossing it. Please refer to the printed or digital version of your examination to answer this multiple-choice question.

Power Plant Diagrams

Nuclear Power Plant

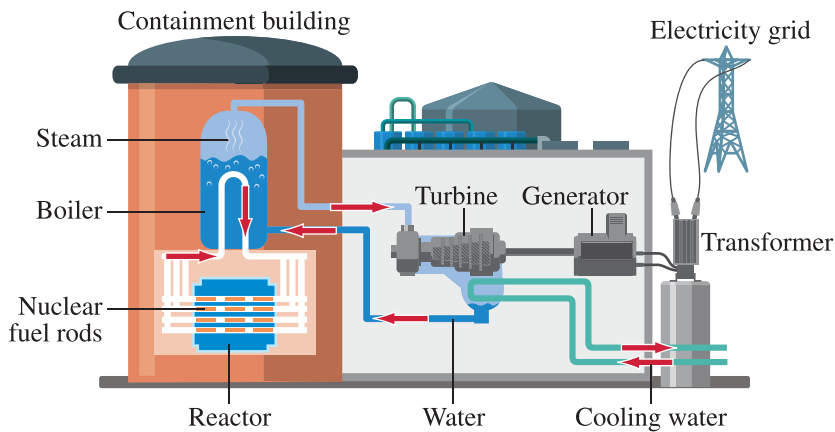

There is a diagram titled “Nuclear Power Plant.” Starting at the bottom left of the plant, there is a large cylindrical tank, labelled “Containment building,” that holds a labelled “Reactor” containing pipes with “Nuclear fuel rods.” The pipes extend outward and then upward on each side of the reactor, coming together into one pipe that extends upward, making a U-turn, and then returning back down into the network of pipes on the right side. Surrounding the U-turn pipe is a large tank, labelled “Boiler,” that is partially filled with bubbling water. “Steam” is shown above the water level. A blue pipe leads from this location to the right, then downward and out of the containment building. This pipe has a right-facing arrow and goes into a structure labelled “Turbine.” A labelled “Generator” is connected to the turbine by a dark grey axle rod. On the right side of the generator, two small wires lead into a labelled “Transformer” that is on top of another small cylinder. The transformer has wires attached leading to a tower labelled “Electricity grid.” There are two green pipes, joined below the turbine, that extend out the right side of the diagram. The pipe on the top has an arrow pointing from the turbine to the right, and the pipe on the bottom, labelled “Cooling water,” has an arrow pointing to the left toward the turbine. Below the turbine and the green pipes, there is a dark blue pipe, labelled “Water,” that travels left and upward back into the partially filled boiler.

Coal-fired Power Plant

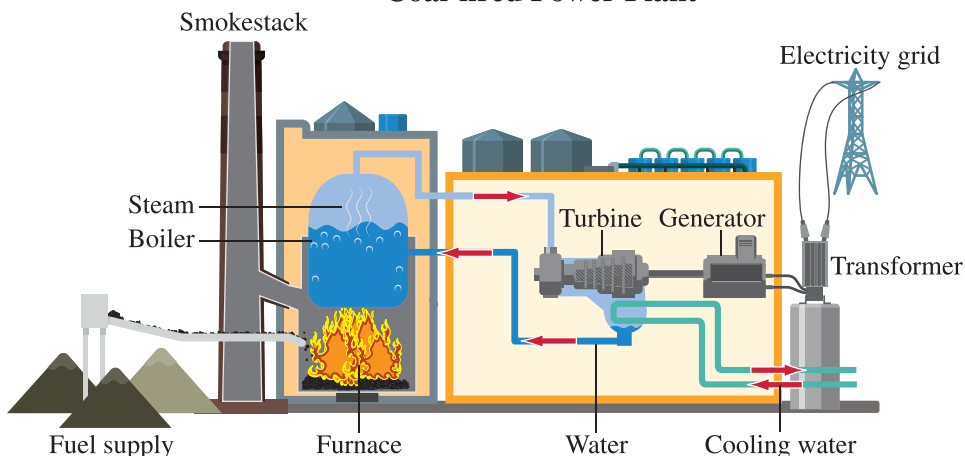

There is a diagram titled “Coal-fired Power Plant.” Starting at the bottom left of the coal-fired power plant, there are three piles of coal, labelled “Fuel supply,” next to a tall chimney labelled “Smokestack.” Coal is being fed by a conveyor belt into a fire contained in a labelled “Furnace.” The fire is heating a tank, labelled “Boiler,” that is partially filled with bubbling water. “Steam” is shown above the water level. A blue pipe leads from this location to the right, then downward and out of the furnace. This pipe has a right-facing arrow and goes into a structure labelled “Turbine.” A labelled “Generator” is connected to the turbine by a dark grey axle rod. On the right side of the generator, two small wires lead into a labelled “Transformer” that is on top of another small cylinder. The transformer has wires attached leading to a tower labelled “Electricity grid.” There are two green pipes, joined below the turbine, that extend out the right side of the diagram. The pipe on the top has an arrow pointing from the turbine to the right, and the pipe on the bottom, labelled “Cooling water,” has an arrow pointing to the left toward the turbine. Below the turbine and the green pipes, there is a dark blue pipe, labelled “Water,” that travels left and upward back into the partially filled boiler.

Phases of the Moon Diagrams

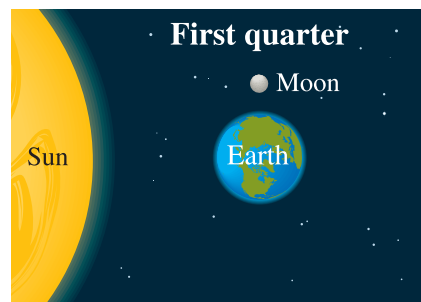
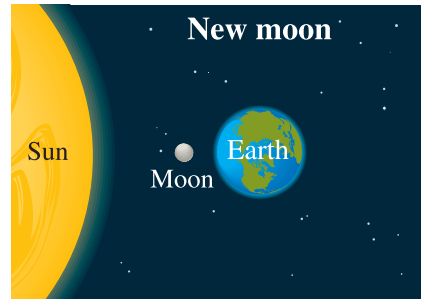
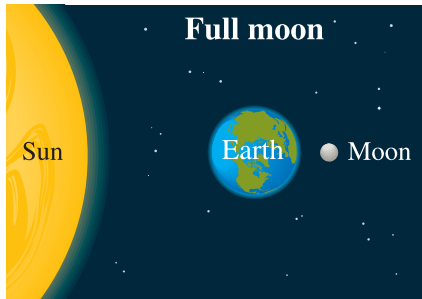

There are four diagrams, each with a large section of a circle labelled "Sun," a medium-sized circle labelled "Earth," showing the northern hemisphere, and a small circle labelled "Moon." In all four diagrams, the Sun and Earth are aligned horizontally, with the Sun at the left of the diagram and Earth near the centre of the diagram. The Moon is in a different position in each diagram.

The top-left diagram, titled "Full moon," shows the Moon to the right of Earth, aligned horizontally with the Sun and Earth.

The top-right diagram, titled "New moon," shows the Moon between the Sun and Earth, aligned horizontally with the Sun and Earth.

The bottom-left diagram, titled "Third quarter," shows the Moon near the bottom of the diagram, aligned vertically with Earth.

The bottom-right diagram, titled "First quarter," shows the Moon near the top of the diagram, aligned vertically with Earth.

Directions

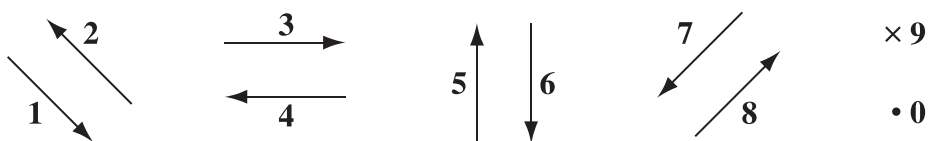

There are ten directions that are numbered. Directions one through eight are represented by arrows. Direction one is toward the bottom right of the page, direction two is toward the top left of the page, direction three is toward the right of the page, direction four is toward the left of the page, direction five is toward the top of the page, direction six is toward the bottom of the page, direction seven is toward the bottom left of the page, direction eight is toward the top right of the page. Direction nine is an X, direction zero is a dot.

Ruler Diagrams

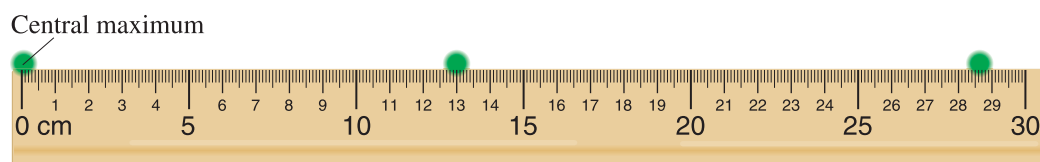

There is a diagram of a ruler showing the top of the ruler lined up with a row of three green dots. The first green dot on the left is labelled "Central maximum." The major divisions on the ruler are numbered from zero to thirty centimetres. Reading from left to right, there is a dot centred at zero centimetres, a dot centred at thirteen decimal zero centimetres, and a dot centred at twenty eight decimal six centimetres.

Unit Analysis

Which of the following unit combinations is appropriate for magnetic field strength?

A. $\frac{\text{N}\cdot\text{m}}{\text{A}}$

B. $\frac{\text{N}\cdot\text{A}}{\text{m}}$

C. $\frac{\text{N}\cdot\text{m}}{\text{C}\cdot\text{s}}$

D. $\frac{\text{N}\cdot\text{s}}{\text{C}\cdot\text{m}}$

A. The product of newtons and metres divided by amperes

B. The product of newtons and amperes divided by metres

C. The product of newtons and metres divided by the product of coulombs and seconds

D. The product of newtons and seconds divided by the product of coulombs and metres

Two-dimensional Collision Diagrams

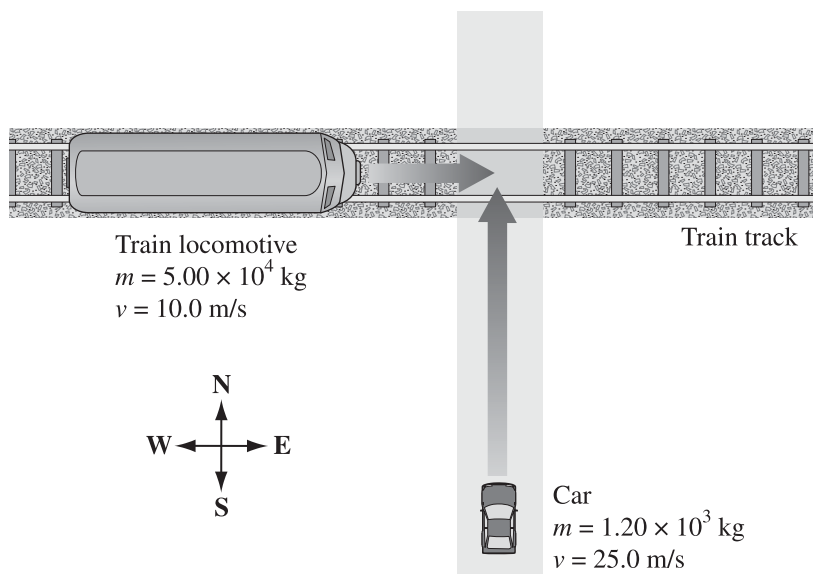

The diagram shows the top-down view of an intersection of a train track and a road. The labelled “train track” runs from left to right across the top of the diagram. On the left end of the train track is a train locomotive labelled “Train locomotive,” “ m is equal to five decimal zero zero times ten exponent four kilograms,” and “ v is equal to ten decimal zero metres per second.” There is an arrow pointing to the right from the front of the locomotive.

In the middle of the diagram from the bottom to the top runs the road. At the bottom end of the road is a car labelled “Car,” “ m equals one decimal two zero times ten exponent three kilograms,” and “ v is equal to twenty-five decimal zero metres per second.” There is an arrow pointing toward the top of the diagram from the front of the car.

The arrow from the car and the arrow from the locomotive both end just before they intersect.

In the bottom left corner of the diagram is a compass rose. The top of the compass is labelled “N,” the right of the compass is labelled “E,” the bottom of the compass is labelled “S,” and the left of the compass is labelled “W.”

Particle Tracks

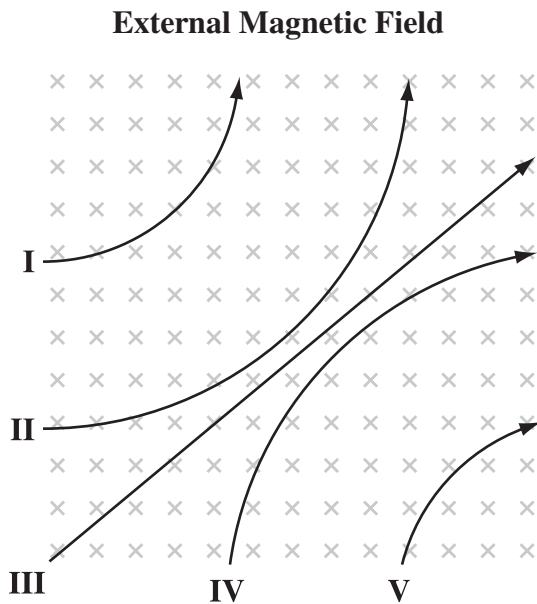

There is a diagram titled “External Magnetic Field” with a square region filled with Xs that represent the direction of a magnetic field. There are five labelled paths. Path one begins at the left side of the square, about a third of the way from the top, and curves counter clockwise, ending in an arrow that points toward the top of the square. Path two begins at the left side of the square, about a third of the way from the bottom, and curves counter-clockwise, ending in an arrow that points toward the top of the square. Path three begins at the bottom left corner of the square and extends linearly, ending in an arrow that points toward the top right of the square. Path four begins at the bottom of the square, about a third of the way from the left, and curves clockwise, ending in an arrow that points toward the right side of the square. Path five begins on the bottom of the square, about a third of the way from the right, and curves clockwise, ending in an arrow that points toward the right side of the square.

The radius of curvature of paths one and five are similar.

The radius of curvature of paths two and four are similar.

The radius of curvature of paths one and five is less than the radius of curvature of paths two and four.

Charged Sphere Diagrams

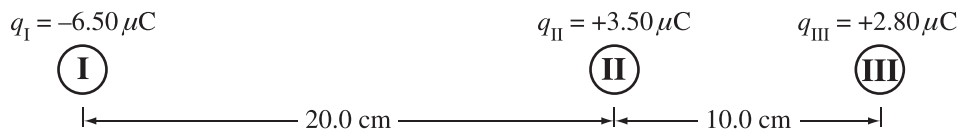

There are three identically sized spheres labelled “one,” “two,” and “three,” in a horizontal line, across the page. Beginning on the left, the first sphere is labelled “q subscript one is equal to negative six decimal five zero microcoulombs.” The middle sphere is labelled “q subscript two is equal to positive three decimal five zero microcoulombs.” The sphere on the right is labelled “q subscript three is equal to positive two decimal eight zero microcoulombs.”

The distance from the centre of sphere one to the centre of sphere two is shown as twenty decimal zero centimetres. The distance from the centre of sphere two to the centre of sphere three is shown as “ten decimal zero centimetres.”

Solenoid Diagrams

Solenoid

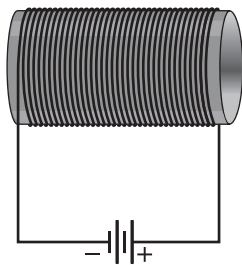

There is a diagram titled “Solenoid” that contains a long, horizontal, hollow cylinder with a coil of wire wrapped around it. On the bottom left side of the coil, the wire wraps across the front of the cylinder. On the bottom right side of the coil, the wire wraps across the back of the cylinder. The bottom left side of the coil is connected to the negative side of a battery and the bottom right side of the coil is connected to the positive side of a battery.

Energy Level Diagrams

Energy Level Diagram

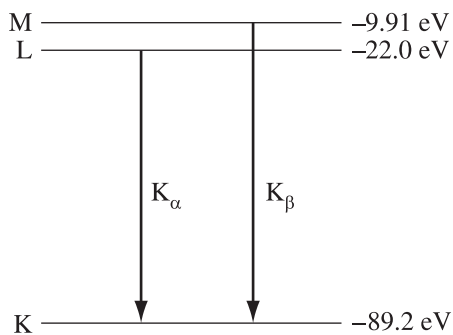

There is a diagram titled “Energy Level Diagram” with three horizontal lines, one above the other. The top line is labelled “M” and “negative nine decimal nine one electron volts.” The middle line is labelled “L” and “negative twenty-two decimal zero electron volts.” The bottom line is labelled “K” and “negative eighty-nine decimal two electron volts.”

There are two vertical arrows that end at energy level K. One arrow begins at energy level L and is labelled “K subscript alpha.” The other arrow begins at energy level M and is labelled “K subscript beta.”

Michelson Apparatus Diagrams

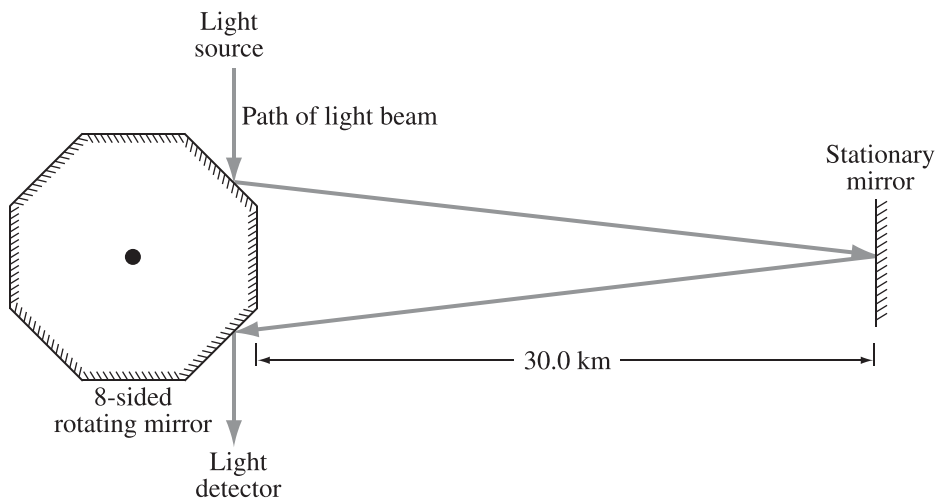

There is a diagram of a Michelson apparatus. On the left of the diagram, there is an octagon labelled “eight-sided rotating mirror.” At the far right of the diagram there is a short, vertical line labelled “Stationary mirror.” The distance between the octagon and the vertical line is labelled as “thirty decimal zero kilometres.”

Above the octagon is a label that reads “Light source.” From this label, a downward vertical arrow labelled “Path of light beam” points down to the upper right diagonal side of the octagon. There is a second arrow from where the first arrow hits the octagon to the stationary mirror. There is a third arrow from where the second arrow hits the stationary mirror to the lower right diagonal side of the octagon. There is a final downward vertical arrow from where the third arrow hits the diagonal side of the octagon to a label that reads “Light detector.”

Charged Plates

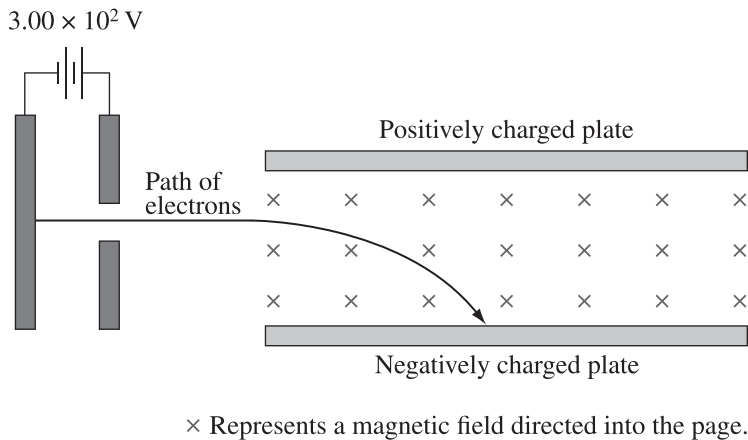

The diagram contains two sets of parallel plates. On the left, there is a vertically oriented set of plates that are both connected to the symbol for a power supply labelled “three decimal zero zero times ten exponent two volts.” The vertical plate on the right side has a gap in its centre. To the right of these vertically oriented plates are two horizontally oriented plates. The top plate is labelled “Positively charged plate” and the bottom plate is labelled “Negatively charged plate.” The region between the horizontal plates is filled with uniformly spaced Xs that represent the direction of a magnetic field.

There is a line, labelled Path of electrons, that begins at the centre of the left vertical plate, extends as a horizontal line that passes through the gap in the second vertical plate, and continues undeflected until it reaches the region between the horizontal oriented plates. As it passes between the plates, it curves downward until it is pointing toward the bottom right corner of the page when it reaches the bottom horizontal plate.

References

National Institute of Standards and Technology, U.S. Department of Commerce. (2019). *The International System of Units (SI)* (NIST Special Publication 330). Retrieved from <https://www.nist.gov>.