

Assessment
Exemplars

Biology

30

Alberta  Government

This document was written primarily for:

Students	✓
Teachers	✓ of Biology 30
Administrators	✓
Parents	
General Audience	
Others	

Distribution: This document is posted on the Alberta Education website at education.alberta.ca.

Copyright 2017, the Crown in Right of Alberta, as represented by the Minister of Education, Alberta Education, Provincial Assessment Sector, 44 Capital Boulevard, 10044 108 Street NW, Edmonton, Alberta T5J 5E6, and its licensors. All rights reserved.

Special permission is granted to **Alberta educators only** to reproduce, for educational purposes and on a non-profit basis, parts of this document that do **not** contain excerpted material.

Excerpted material in this document **shall not** be reproduced without the written permission of the original publisher (see credits, where applicable).

Contents

Biology 30 Assessment Exemplars.....	1
Unit A.....	2
Unit B.....	30
Unit C.....	55
Unit D.....	78

You can find diploma examination-related materials on the Alberta Education website at education.alberta.ca.

Biology 30 Assessment Exemplars

These Biology 30 assessment exemplars were developed by the Provincial Assessment Sector in cooperation with the Curriculum Branch of Alberta Education to assist teachers with the interpretation of curricular outcomes in the revised program of studies (implemented in September 2008). The assessment exemplars, which include multiple-choice and numerical-response questions, illustrate how a particular concept can be assessed in a machine-scored format. Teachers are encouraged to use other assessment tools as well as machine-scored questions to assess the learning of their students.

This exemplar document parallels the *Biology 30 Program of Studies*. Each outcome is identified by a letter that indicates the unit of study (A, B, C, or D); by a number that indicates the general learner outcome within the unit; and by a number that indicates the specific outcome. Each specific outcome is further classified as knowledge (k); science, technology, and society (STS); or skills (s). For example, A2.6k indicates that the concept is from Unit A, general outcome 2, specific outcome 6, and that the outcome is knowledge-based.

Outcomes in the program of studies contain verbs that indicate the cognitive expectations of the outcome. In this exemplars document, questions classified as knowledge (K) require students to identify structures or recall facts. Questions classified as comprehension and application (C/A) require students to make connections between concepts or to take information they already know and apply it to new contexts. Questions classified as higher mental activities (HMA) require students to build new connections; integrate several concepts; and analyze, evaluate, or synthesize information. Further details related to cognitive levels can be found in the [*Biology 30 Information Bulletin*](#).

This exemplars document is neither exhaustive nor prescriptive. Its purpose is simply to provide a variety of useful examples of how specific outcomes in the *Biology 30 Program of Studies* can be assessed.

The exemplars from each of the four units can be found on the following pages:

- Unit A: Pages 2–29
- Unit B: Pages 30–54
- Unit C: Pages 55–77
- Unit D: Pages 78–97

Unit A

Use the following information to answer questions 1 and 2.

People with Alzheimer disease have a lower-than-normal level of acetylcholine in the brain. Cholinesterase inhibitors, such as the drug donepezil, can slow the development of symptoms in the early-to-middle stages of Alzheimer disease, but they cannot stop the progression of the disease. The donepezil molecule has a shape that allows it to attach to the active site on cholinesterase.

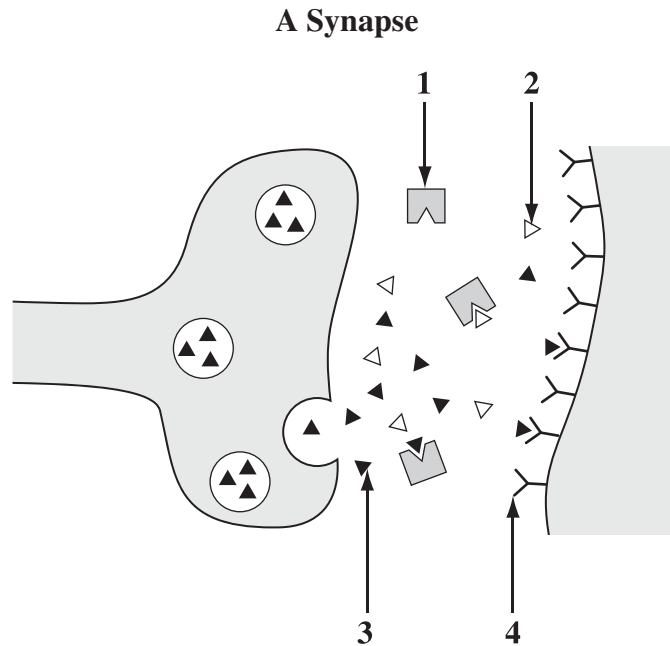

1. In the diagram above, donepezil and acetylcholine are numbered, respectively,

- A. 1 and 3
- B. 1 and 4
- C. 2 and 3
- D. 2 and 4

Answer: C

Outcome: A1.1k, A1.2s, A1.3sts

Cognitive level: C/A

2. Which of the following statements describes an effect of donepezil on synaptic transmission?
- A. Donepezil breaks down acetylcholine so that less acetylcholine is present in the synapse.
 - B. Donepezil replaces cholinesterase so that more acetylcholine is present in the synapse.
 - C. Donepezil blocks the release of acetylcholine so that less acetylcholine is present in the synapse.
 - D. Donepezil prevents the breakdown of acetylcholine so that more acetylcholine is present in the synapse.

Answer: D

Outcome: A1.1k, A1.3sts

Cognitive level: C/A

Use the following information to answer question 3.

In a research study on the detection of odours, a group composed of men, women of reproductive age, postmenopausal women, and children were asked to smell gradually decreasing concentrations of specific familiar chemicals. The women of reproductive age were more able to detect weaker odours than were the men, postmenopausal women, and the children. The researchers concluded that female sex hormones might increase sensitivity to familiar odours.

3. The inference that can be made from the study described above is that compared to men, postmenopausal women, and children, women of reproductive age have
- A. more receptors for odour detection
 - B. a lower threshold level for familiar odours
 - C. the ability to interpret odours more quickly
 - D. the ability to adapt to familiar odours more quickly

Answer: B

Outcome: A1.1k, A1.6k, A1.3s

Cognitive level: C/A

Use the following information to answer numerical-response question 1.

The pupillary reflex is a reflex that occurs in response to varying intensities of light entering the eye.

Some Events in the Pupillary Reflex

- 1 Pupil diameter changes
- 2 Motor neuron depolarizes
- 3 Light receptors stimulated
- 4 Sensory neuron depolarizes

Numerical Response

1. The order in which the events numbered above occur during the pupillary reflex is _____, _____, _____, and _____.

(Record all **four digits** of your answer in the numerical-response section on the answer sheet.)

Answer: 3421

Outcome: A1.3k, A1.4k

Cognitive level: K

4. Which of the following rows describes the change in heart rate, blood flow to the skin, and glucose storage that would be expected immediately following stimulation of the sympathetic nervous system?

Row	Heart Rate	Blood Flow to Skin	Glucose Storage
A.	Increased	Decreased	Decreased
B.	Increased	Increased	Increased
C.	Decreased	Decreased	Decreased
D.	Decreased	Increased	Increased

Answer: A

Outcome: A1.2k

Cognitive level: K

Use the following information to answer numerical-response question 2 and questions 5 and 6.

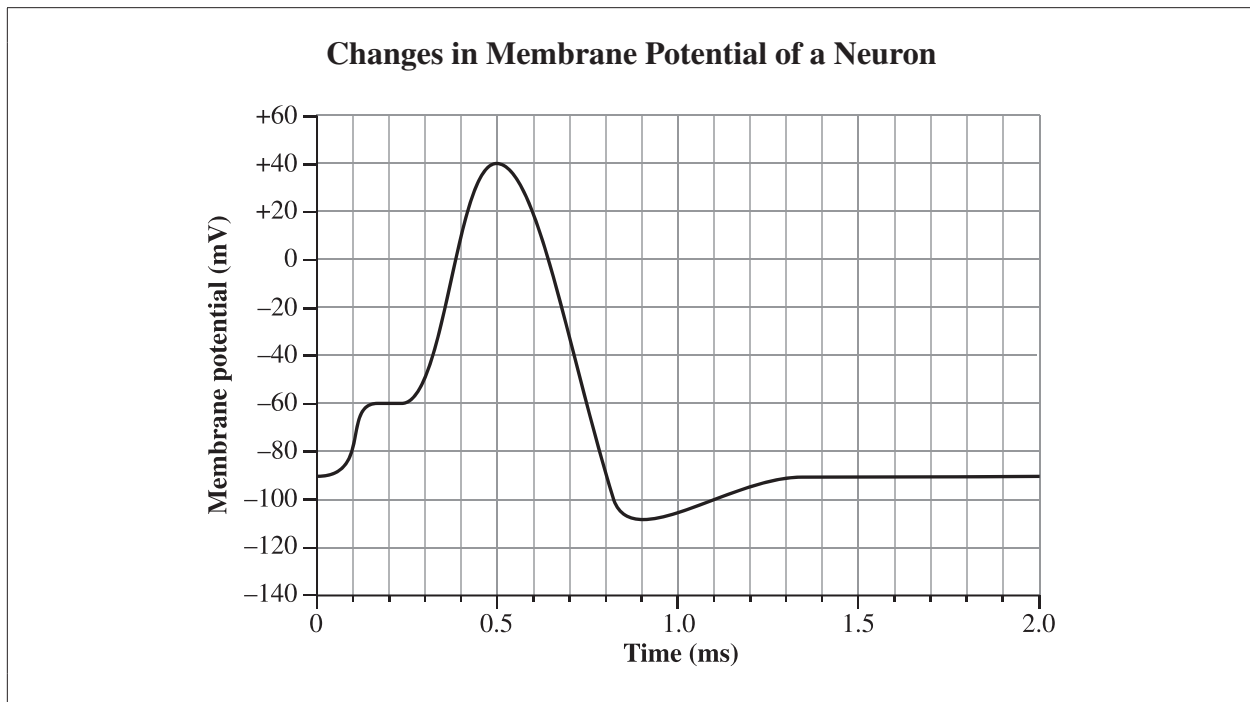

Numerical Response

2. What is the resting membrane potential for the neuron represented in the graph above, expressed as two digits, and what is the maximum membrane potential during depolarization, expressed as two digits?

Number: _____
Membrane Potential: **Resting** **Maximum During Depolarization**

(Record all **four digits** of your answer in the numerical-response section on the answer sheet.)

Answer: 9040

Outcome: A1.1k, A1.3s

Cognitive level: C/A

5. In the graph on the previous page, the ion movement that occurs between 0.3 ms and 0.5 ms is **best** described as

- A. sodium ions moving into the axon
- B. sodium ions moving out of the axon
- C. potassium ions moving into the axon
- D. potassium ions moving out of the axon

Answer: A

Outcome: A1.1k, A1.3s

Cognitive level: C/A

6. On the graph above, the part of an action potential that occurs between 0.5 ms and 1.0 ms is **best** described as the

- A. refractory period, which is when repolarization occurs
- B. refractory period, which is when depolarization occurs
- C. threshold period, which is when repolarization occurs
- D. threshold period, which is when depolarization occurs

Answer: A

Outcome: A1.1k, A1.3s

Cognitive level: C/A

Use the following information to answer question 7.

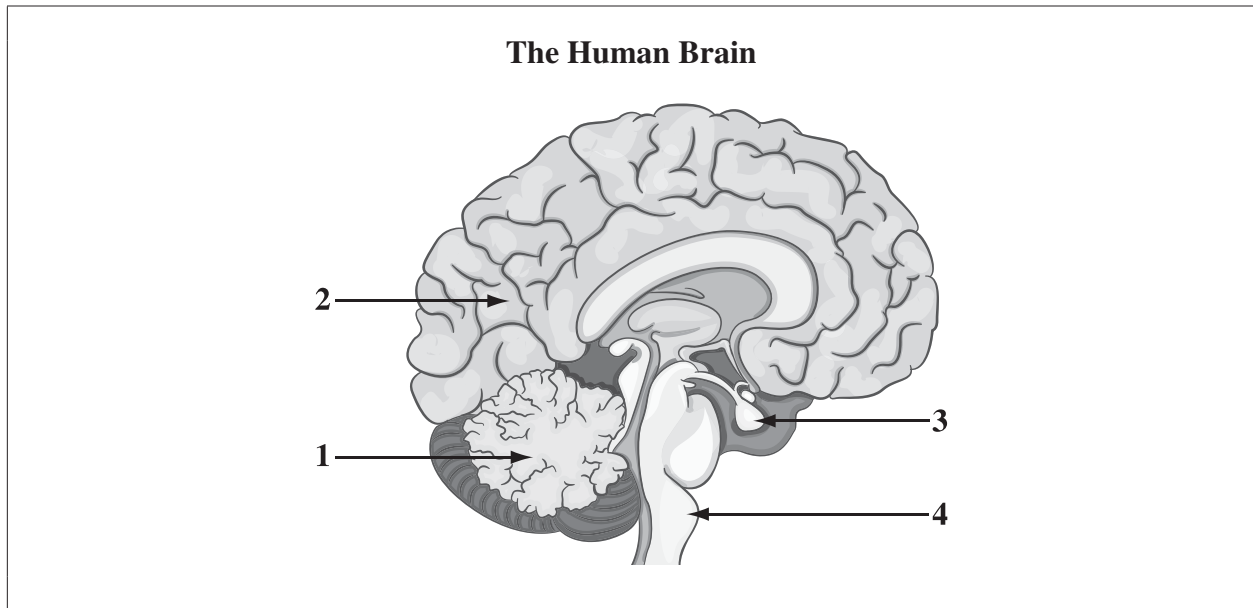

7. The area of the brain that controls the sympathetic and parasympathetic nervous systems is numbered

- A. 1
- B. 2
- C. 3
- D. 4

Answer: D

Outcome: A1.2k, A1.2s

Cognitive level: K

8. The division of the nervous system that is **directly** responsible for physiological responses to fear is the
- A. sensory nervous system
 - B. somatic nervous system
 - C. sympathetic nervous system
 - D. parasympathetic nervous system

Answer: C

Outcome: A1.2k

Cognitive level: K

Use the following information to answer question 9.

Biofeedback consists of conscious efforts to control body responses that are usually involuntary.

9. The part of the brain in which conscious efforts to control body responses through biofeedback originate is the
- A. medulla
 - B. cerebrum
 - C. cerebellum
 - D. hypothalamus

Answer: B

Outcome: A1.2k

Cognitive level: K

Use the following information to answer questions 10 to 12.

People with Refsum disease cannot metabolize phytanic acid, which results in a buildup of phytanic acid in body tissues and impairs the development of the myelin sheath on neurons. Symptoms of Refsum disease include hearing and vision loss, decreased muscle coordination, and a reduced sense of smell.

The Human Brain

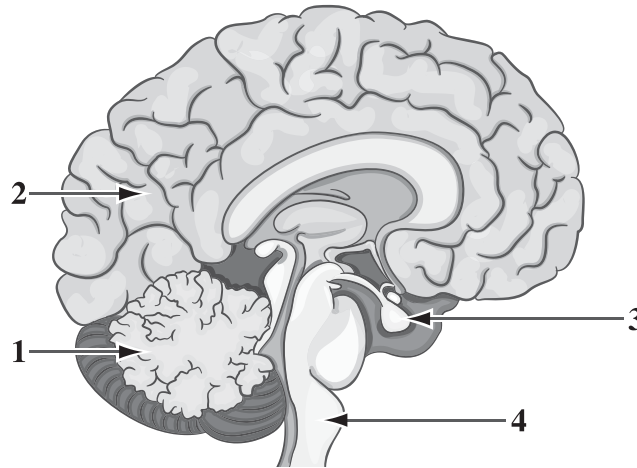

10. In the diagram above, two areas of the brain whose function can be affected in a person with Refsum disease are numbered

- A. 1 and 2
- B. 1 and 4
- C. 2 and 3
- D. 3 and 4

Answer: A

Outcome: A1.2k, A1.2s

Cognitive level: K

11. Which of the following rows identifies the structure of a neuron affected by a buildup of phytanic acid in people with Refsum disease and describes the expected effect of phytanic acid buildup on nerve impulse transmission?

Row	Neuron Structure	Expected Effect
A.	Axon	Nerve impulses travel faster than normal
B.	Axon	Nerve impulses travel slower than normal
C.	Cell body	Nerve impulses travel faster than normal
D.	Cell body	Nerve impulses travel slower than normal

Answer: B

Outcome: A1.1k

Cognitive level: C/A

Use the following additional information to answer question 12.

Symptoms of vision loss in people with Refsum disease include clouding of the lens, a condition known as cataracts, and impaired night vision.

The Human Eye

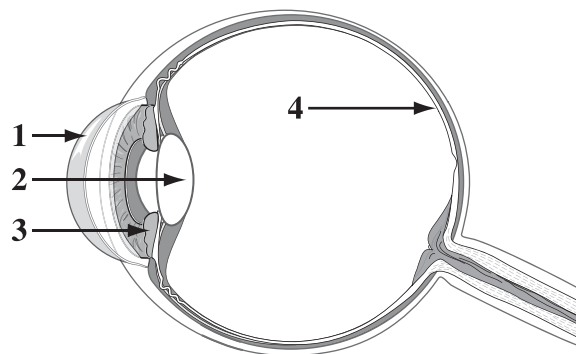

12. Two structures of the eye that are associated with the symptoms of the type of vision loss in people with Refsum disease are
- A. 1 and 4
 - B. 2 and 3
 - C. 2 and 4
 - D. 3 and 4

Answer: C

Outcome: A1.4k, A1.2s

Cognitive level: C/A

Use the following information to answer question 13.

After a man accidentally hits his thumb with a hammer, he initially does not feel pain, but immediately withdraws his hand.

13. Which of the following descriptions **best** explains the reason the man initially does not feel pain?
- A. The threshold of the receptors in the man's thumb has been so greatly exceeded that they do not pass the message to the brain.
 - B. There are too many nerve impulses travelling to the brain that the brain is unable to interpret the signal fast enough.
 - C. Neural processing occurred in the spinal cord first, which caused the man to quickly remove his thumb from further damage.
 - D. Sensory receptors in the man's thumb were damaged by the hammer and were unable to initiate a stimulus to the sensory nerve.

Answer: C

Outcome: A1.3k

Cognitive level: C/A

14. The correct order of structures involved in a reflex arc is
- A. receptor, sensory neuron, effector, motor neuron
 - B. motor neuron, interneuron, sensory neuron, effector
 - C. sensory neuron, receptor, interneuron, motor neuron
 - D. receptor, sensory neuron, interneuron, motor neuron

Answer: D

Outcome: A1.3k

Cognitive level: K

Use the following information to answer numerical-response question 3.

Some Structures of the Nervous System

- 1 Optic nerve
- 2 Photoreceptor
- 3 Occipital lobe

Numerical Response

3. After light enters the eye, the order in which the structures numbered above are stimulated is _____, _____, and _____.

(Record all **three digits** of your answer in the numerical-response section on the answer sheet.)

Answer: 213

Outcome: A1.4k

Cognitive level: K

Use the following information to answer question 15.

Erectile dysfunction, which is defined as the inability to maintain an erection, can sometimes be treated with the drug sildenafil citrate. A side effect that may occur while taking sildenafil citrate is difficulty distinguishing between the colours blue and green.

The Human Eye

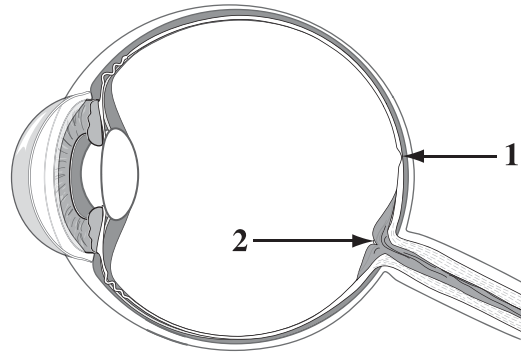

15. The cells in the eye that are affected by sildenafil citrate are primarily found in
- A. location 1, and these cells are known as rods
 - B. location 1, and these cells are known as cones
 - C. location 2, and these cells are known as rods
 - D. location 2, and these cells are known as cones

Answer: B

Outcome: A1.4k, A1.2s, A1.3sts

Cognitive level: K

Use the following information to answer numerical-response question 4.

When a car's airbag deploys, there is a rapid increase in air pressure that results from the rapid expansion of gases inside the airbag. This expansion causes pressure waves that can damage the inner ear.

Structures of the Human Ear

- 1 Ossicles
- 2 Cochlea
- 3 Auditory canal
- 4 Tympanic membrane

Numerical Response

4. The sequence in which the highly compressed pressure waves created by the deployment of an airbag travel through the structures of the human ear is _____, _____, _____, and _____.

(Record all **four digits** of your answer in the numerical-response section on the answer sheet.)

Answer: 3412

Outcome: A1.5k

Cognitive level: K

16. Which of the following rows identifies the structure of the ear that converts mechanical vibrations into electrochemical impulses and the structure of the ear where electrochemical impulses are **first** produced?

Row	Structure That Converts Vibrations into Impulses	Structure Where Impulses are First Produced
A.	Cochlea	Ossicles
B.	Cochlea	Organ of Corti
C.	Semicircular canals	Ossicles
D.	Semicircular canals	Organ of Corti

Answer: B

Outcome: A1.5k

Cognitive level: K

17. The lobe of the brain in which sounds are **first** analyzed is the

- A. frontal lobe
- B. parietal lobe
- C. temporal lobe
- D. occipital lobe

Answer: C

Outcome: A1.2k

Cognitive level: K

Use the following information to answer numerical-response question 5.

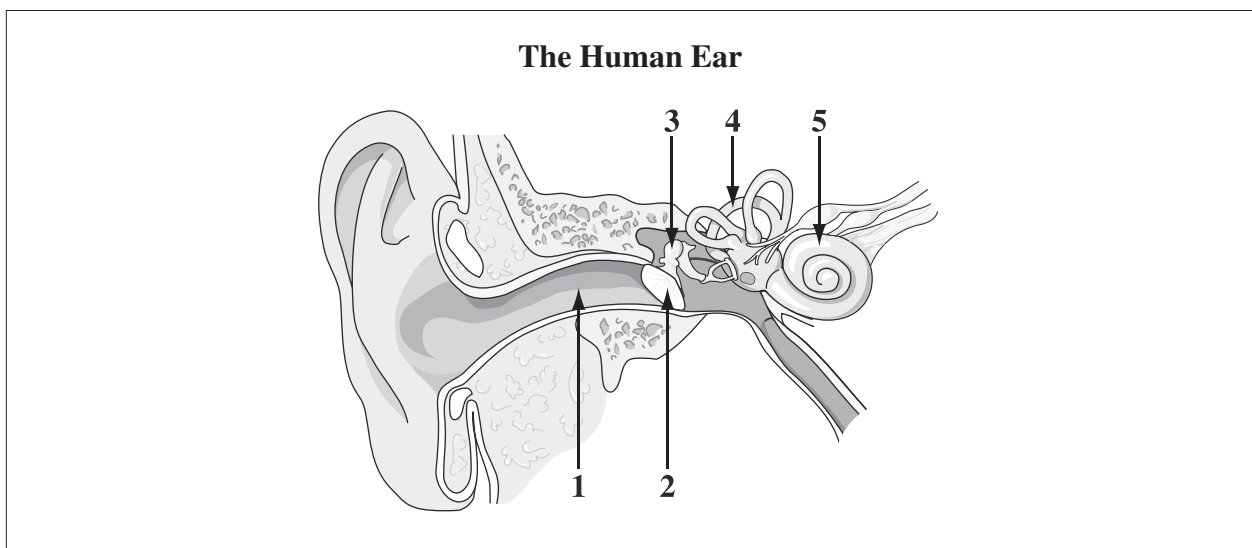

Numerical Response

5. Four structures numbered above that are involved in hearing are _____, _____, _____, and _____.

(Record all **four digits** of your answer **in any order** in the numerical-response section on the answer sheet.)

Answer: 1235 (any order)

Outcome: A1.5k, A1.2s

Cognitive level: K

Use the following information to answer numerical-response question 6.

Some Cell Types	Some Disorders
<p>1 Rod cells</p> <p>2 Cone cells</p> <p>3 Cochlea hair cells</p> <p>4 Taste receptor cells</p> <p>5 Semi-circular canal hair cells</p>	<p>Colour-blindness—a genetic disorder that results in the inability to detect certain colours of light</p> <p>Neural deafness—the inability to detect sound as a result of damage to sensory structures in the inner ear</p> <p>Permanent vertigo—a severe balance disorder that usually results from physical trauma to the ear</p>

Numerical Response

- 6.** Match three of the cell types numbered above with the disorder that is **most closely** associated with each cell type.

Number: _____
Disorder: **Colour-blindness** **Neural deafness** **Permanent vertigo**

(Record all **three digits** of your answer in the numerical-response section on the answer sheet.)

Answer: 235

Outcome: A1.4k, A1.5k, A1.6k, A1.3s

Cognitive level: C/A

Use the following information to answer questions 18 and 19.

Drinking coffee may protect a person against Parkinson disease, a neurological disorder resulting from reduced production of the neurotransmitter dopamine by cells in the brain.

In an experiment, a group of mice was given caffeine in an amount equivalent to approximately one cup of coffee for a human and a second group of mice was not given caffeine. Both groups of mice were then given MPTP, a chemical that destroys dopamine-producing neurons, to induce symptoms similar to those of Parkinson disease.

The mice that were given caffeine before being given MPTP showed a much smaller reduction in dopamine levels than the mice that were not given caffeine before being given MPTP.

- 18.** The manipulated variable in the experiment described above is the
- A.** ingestion of MPTP
 - B.** ingestion of caffeine
 - C.** production of dopamine by brain cells
 - D.** destruction of dopamine-producing neurons

Answer: B

Outcome: A1.1k, A1.1sts

Cognitive level: C/A

- 19.** In the experiment described above, two variables that the researchers would want to keep the same in both groups of mice are the
- A.** age of the mice and the time that caffeine is given
 - B.** amount of MPTP ingested and the age of the mice
 - C.** size of the mice and the amount of dopamine produced
 - D.** amount of MPTP ingested and the amount of dopamine produced

Answer: B

Outcome: A1.1k, A1.1sts

Cognitive level: C/A

20. Which of the following rows identifies the hormone that stimulates the release of cortisol, the gland that secretes cortisol, and an effect of cortisol?

Row	Hormone	Gland	Effect
A.	ADH	Adrenal gland	Increased conversion of amino acids to glucose
B.	ADH	Pituitary gland	Increased water reabsorption
C.	ACTH	Adrenal gland	Increased conversion of amino acids to glucose
D.	ACTH	Pituitary gland	Increased water reabsorption

Answer: C

Outcome: A2.1k, A2.2k, A2.3k

Cognitive level: K

Use the following information to answer numerical-response question 7.

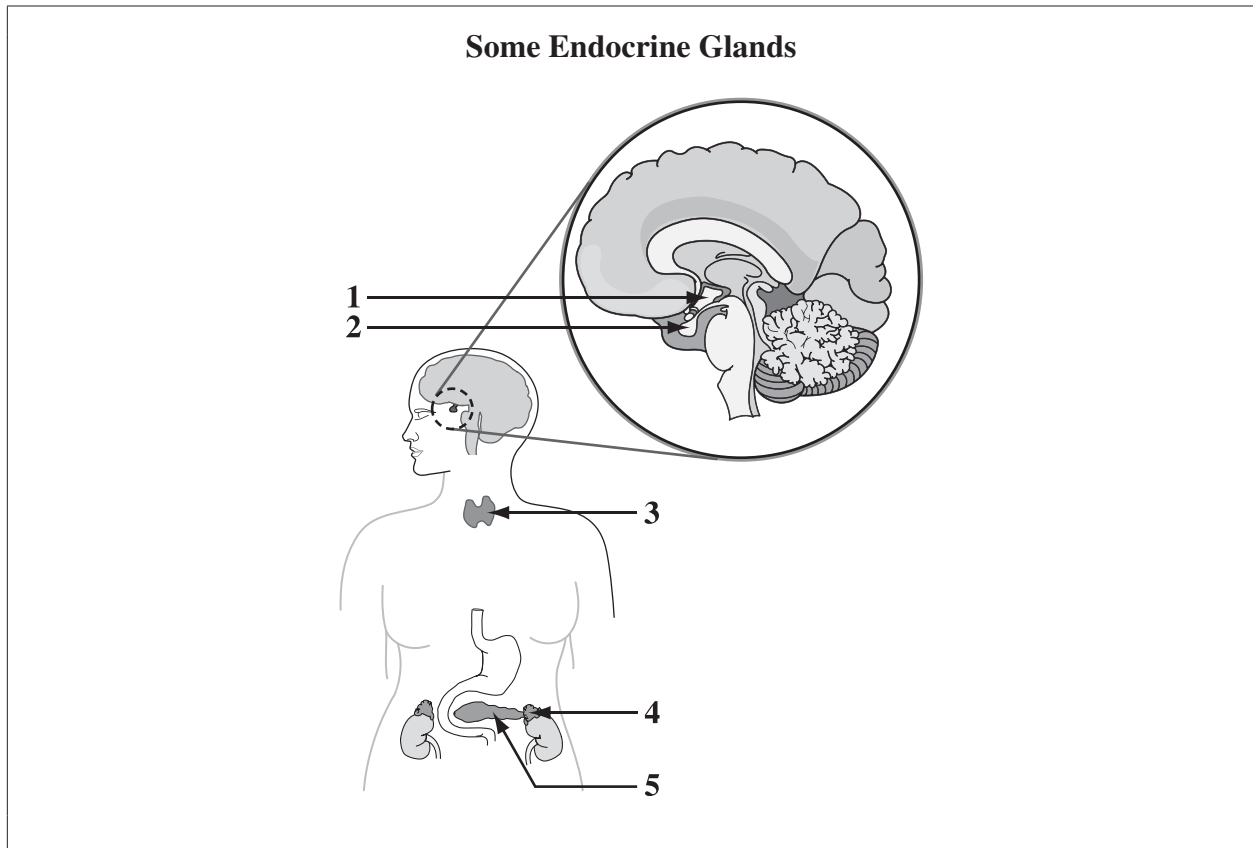

Numerical Response

7. The three glands numbered above that are involved in the feedback control of cortisol secretion are _____, _____, and _____.

(Record all **three digits** of your answer **in any order** in the numerical-response section on the answer sheet.)

Answer: 124 (Any order)

Outcome: A2.1k, A2.2k

Cognitive level: K

Use the following information to answer questions 21 and 22.

Uncontrolled cell division in cells of the thyroid can lead to the formation of a tumour in the thyroid gland. Thyroid tumours are often treated with a combination of surgery, radioactive iodine, and thyroid medication.

- 21.** A change in hormone level that would be expected immediately following surgical removal of the thyroid gland is
- A.** a decrease in both thyroxine and TSH levels
 - B.** an increase in both thyroxine and TSH levels
 - C.** an increase in thyroxine level and a decrease in TSH level
 - D.** a decrease in thyroxine level and an increase in TSH level

Answer: D

Outcome: A2.2k, A2.4k, A2.1sts

Cognitive level: C/A

- 22.** Following surgical removal of the thyroid gland, thyroid medication is often prescribed in order to increase
- A.** sodium ion reabsorption and increase water retention
 - B.** sodium ion reabsorption and decrease water retention
 - C.** the rate of metabolism and increase the rate of heat production
 - D.** the rate of metabolism and decrease the rate of heat production

Answer: C

Outcome: A2.2k, A2.3k, A2.4k, A2.1sts

Cognitive level: C/A

Use the following information to answer question 23.

Chemicals found in alcohol and tea have a diuretic effect. Diuretics cause the body to produce a greater-than-normal volume of urine.

23. The hormone whose effect is inhibited by diuretics is

- A.** TSH
- B.** ADH
- C.** insulin
- D.** cortisol

Answer: B

Outcome: A2.2k, A2.3k

Cognitive level: C/A

Use the following information to answer numerical-response question 8 and question 24.

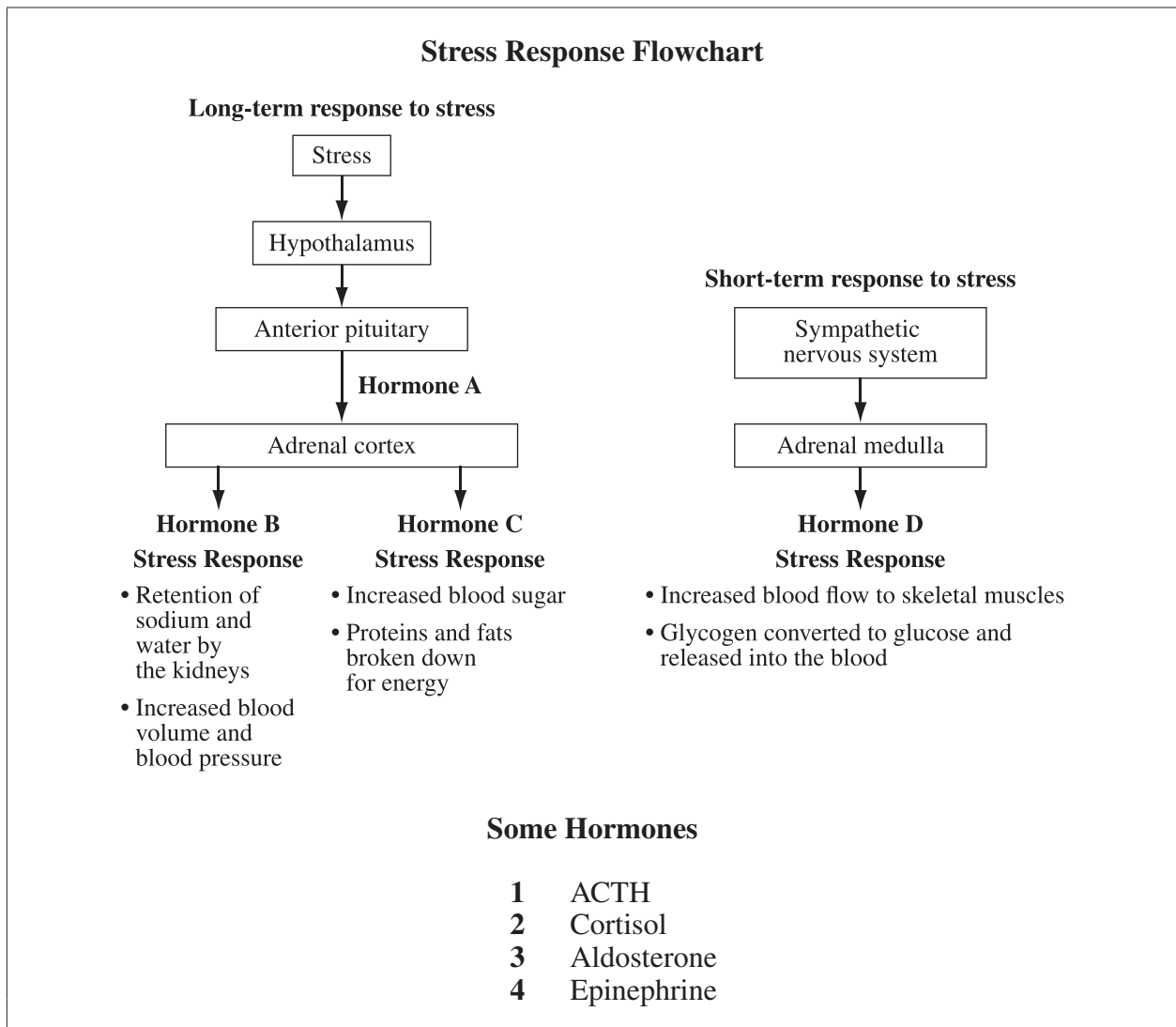

Numerical Response

8. Match each of the hormones numbered above with the hormones represented in the stress response flowchart below.

Number: _____
 Hormone: A B C D

(Record all **four digits** of your answer in the numerical-response section on the answer sheet.)

Answer: 1324

Outcome: A2.2k, A2.3k

Cognitive level: C/A

- 24.** The short-term response to stress occurs faster than the long-term response to stress because
- A.** blood from the adrenal gland travels faster than does blood from the pituitary gland
 - B.** the adrenal gland responds to nervous stimulation, which is faster than hormonal stimulation
 - C.** hormones from the adrenal gland act on cells more quickly than hormones from the pituitary gland
 - D.** the adrenal gland responds to hormonal stimulation, which is faster than nervous stimulation

Answer: B

Outcome: A2.5k, A2.2k

Cognitive level: C/A

25. The hormone that plays a role in returning the sodium ion concentration in the blood to homeostatic levels after heavy exercise is

- A.** cortisol
- B.** thyroxine
- C.** aldosterone
- D.** epinephrine

Answer: C

Outcome: A2.2k, A2.3k

Cognitive level: K

Use the following information to answer questions 26 and 27.

The hormone ACTH helps to regulate the nervous system. It also helps the body respond to changes in sleep patterns. The release of ACTH is suppressed during sleep but increases before a person awakes. The regulation of ACTH is shown in the feedback loop below.

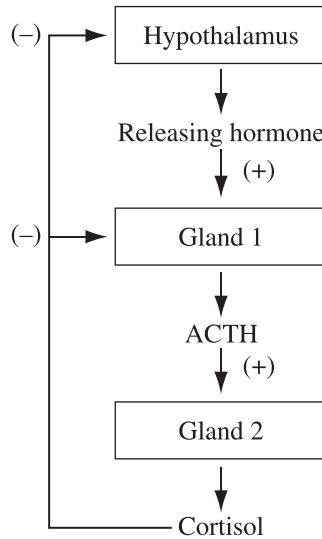

26. A possible reason for the suppression of ACTH during sleep is that during sleep, the
- A. secretion of cortisol is decreased
 - B. activity in the hypothalamus is increased
 - C. activity in the pituitary gland is increased
 - D. secretion of releasing hormone is decreased

Answer: D

Outcome: A2.1k, A2.2k, A2.4k

Cognitive level: C/A

Use the following additional information to answer question 27.

Researchers studying the hormonal control of sleep patterns divided volunteers into two groups. One group of volunteers were told that they would be awakened at 6:00 a.m. and the other group were told they would be awakened at 9:00 a.m. Each volunteer had blood samples taken throughout the night.

Both groups were awakened at 6:00 a.m. The group expecting to be awakened at 6:00 a.m. showed increased levels of ACTH in their blood at 5:00 a.m., but the level of ACTH remained low in the blood of the group expecting to be awakened at 9:00 a.m.

27. Which of the following explanations **best** describes the results of the study described above?
- A. Stimulation of the adrenal gland increased in the group that expected to be awakened at 6:00 a.m.
 - B. Stimulation of the thyroid gland increased in the group that expected to be awakened at 6:00 a.m.
 - C. Stimulation of the adrenal gland decreased in the group that expected to be awakened at 6:00 a.m.
 - D. Stimulation of the thyroid gland decreased in the group that expected to be awakened at 6:00 a.m.

Answer: A

Outcome: A2.2k, A2.4k

Cognitive level: C/A

28. The hormonal response expected as a direct result of a lower-than-normal blood calcium level is

- A.** decreased secretion of PTH and increased deposition of calcium in the bones
- B.** decreased secretion of calcitonin and increased deposition of calcium in the bones
- C.** increased secretion of PTH and increased release of calcium from the bones
- D.** increased secretion of calcitonin and increased release of calcium from the bones

Answer: C

Outcome: A2.2k, A2.4k

Cognitive level: C/A

29. The release of thyroxine from the thyroid gland is directly regulated by

- A.** TSH
- B.** PTH
- C.** iodine
- D.** thyroxine

Answer: A

Outcome: A2.2k

Cognitive level: K

30. A symptom in a person with hyperthyroidism is

- A.** weight loss
- B.** feeling tired
- C.** intolerance to cold
- D.** slowed mental processes

Answer: A

Outcome: A2.6k, A2.2k

Cognitive level: C/A

31. Two hormones that work in opposition to each other are

- A. TSH and thyroxine
- B. insulin and glucagon
- C. ADH and aldosterone
- D. prolactin and oxytocin

Answer: B

Outcome: A2.2k, A2.3k

Cognitive level: K

Use the following information to answer question 32.

Diabetes insipidus is a disorder in which the body fails to produce sufficient levels of ADH.

32. A symptom **most likely** expected in a person who has diabetes insipidus is

- A. the production of large amounts of dilute urine
- B. a decrease in the glucose concentration in the blood
- C. an increase in the glucose concentration in the urine
- D. the production of small amounts of concentrated urine

Answer: A

Outcome: A2.6k, A2.2k

Cognitive level: C/A

Unit B

Use the following information to answer numerical-response question 9.

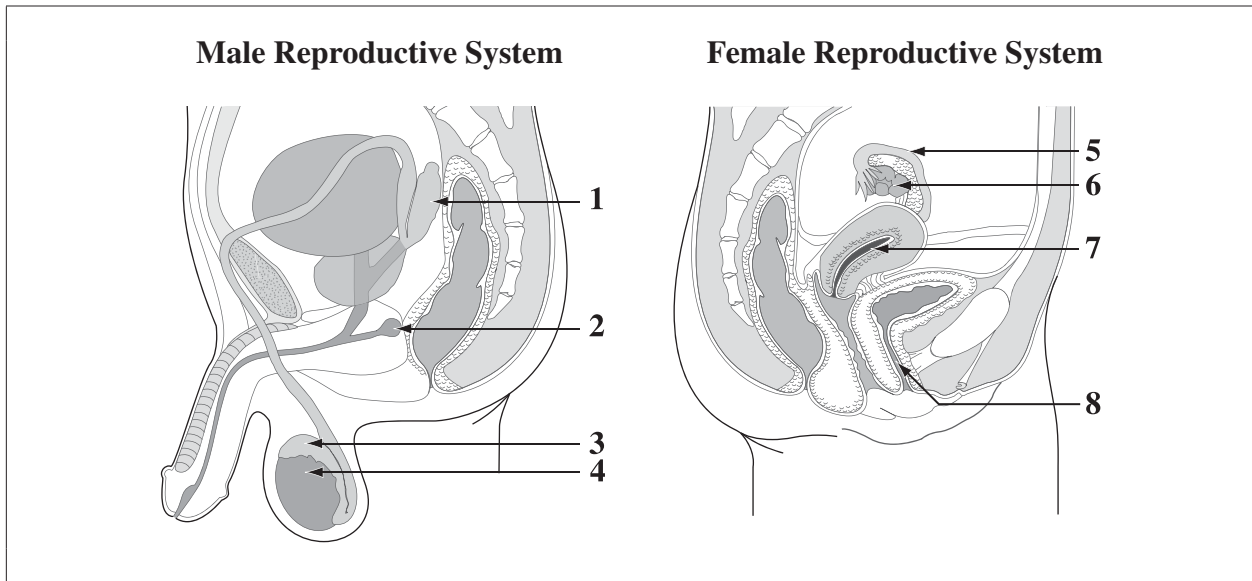

Numerical Response

9. Match four structures of the male and female reproductive systems numbered above with their descriptions given below.

Number:	_____	_____	_____	_____
Description:	Site of spermatogenesis	Site of oogenesis	Site of fructose production	Normal site of fertilization

(Record all **four digits** of your answer in the numerical-response section on the answer sheet.)

Answer: 4615

Outcome: B1.1k, B1.2k, B1.2s

Cognitive level: K

Use the following information to answer question 33.

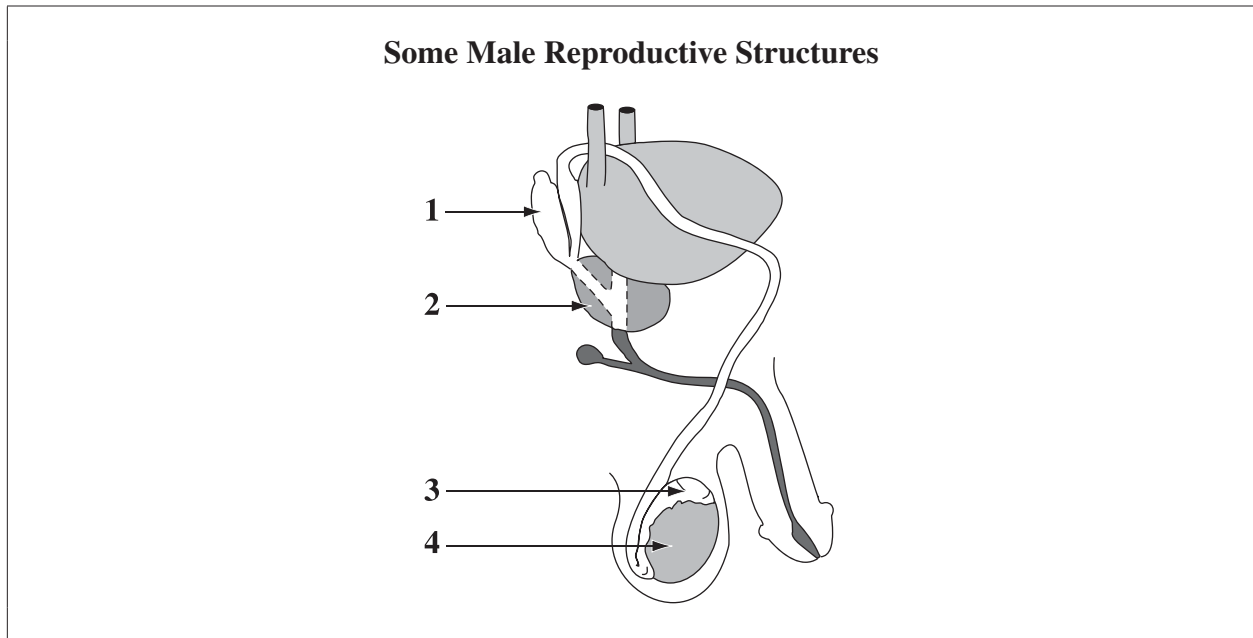

33. Which of the following rows identifies the male reproductive structure in which sperm are produced and the gland that secretes an alkaline buffer?

Row	Structure	Gland
A.	3	1
B.	3	2
C.	4	1
D.	4	2

Answer: D

Outcome: B1.2k, B1.2s

Cognitive level: K

34. Which of the following rows matches a substance that is present in semen with the structure that produces the substance?

Row	Substance	Structure
A.	Sperm	Vas deferens
B.	Fructose	Cowper's gland
C.	Alkaline buffer	Prostate gland
D.	Testosterone	Interstitial cells

Answer: C

Outcome: B1.2k

Cognitive level: K

Use the following information to answer numerical-response question 10.

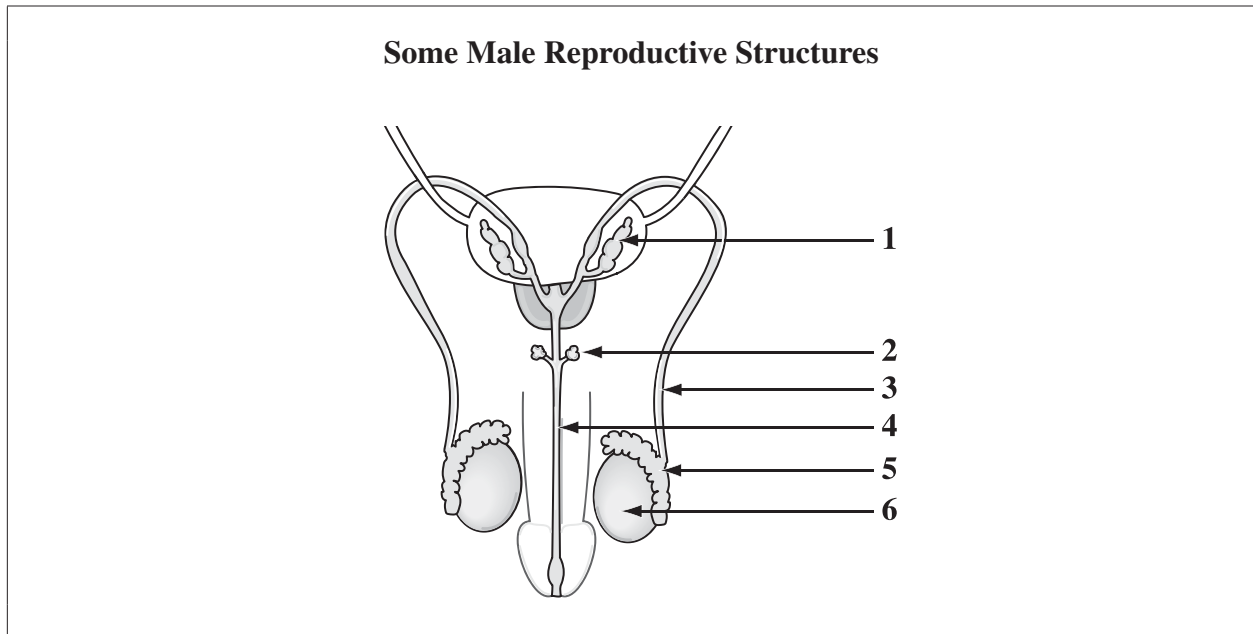

Numerical Response

10. The order of the structures numbered above through which sperm cells travel from the time when spermatogenesis occurs to the time when ejaculation occurs is _____, _____, _____, and _____.

(Record all **four digits** of your answer in the numerical-response section on the answer sheet.)

Answer: 6534

Outcome: B1.2k, B1.2s

Cognitive level: K

Use the following information to answer questions 35 and 36.

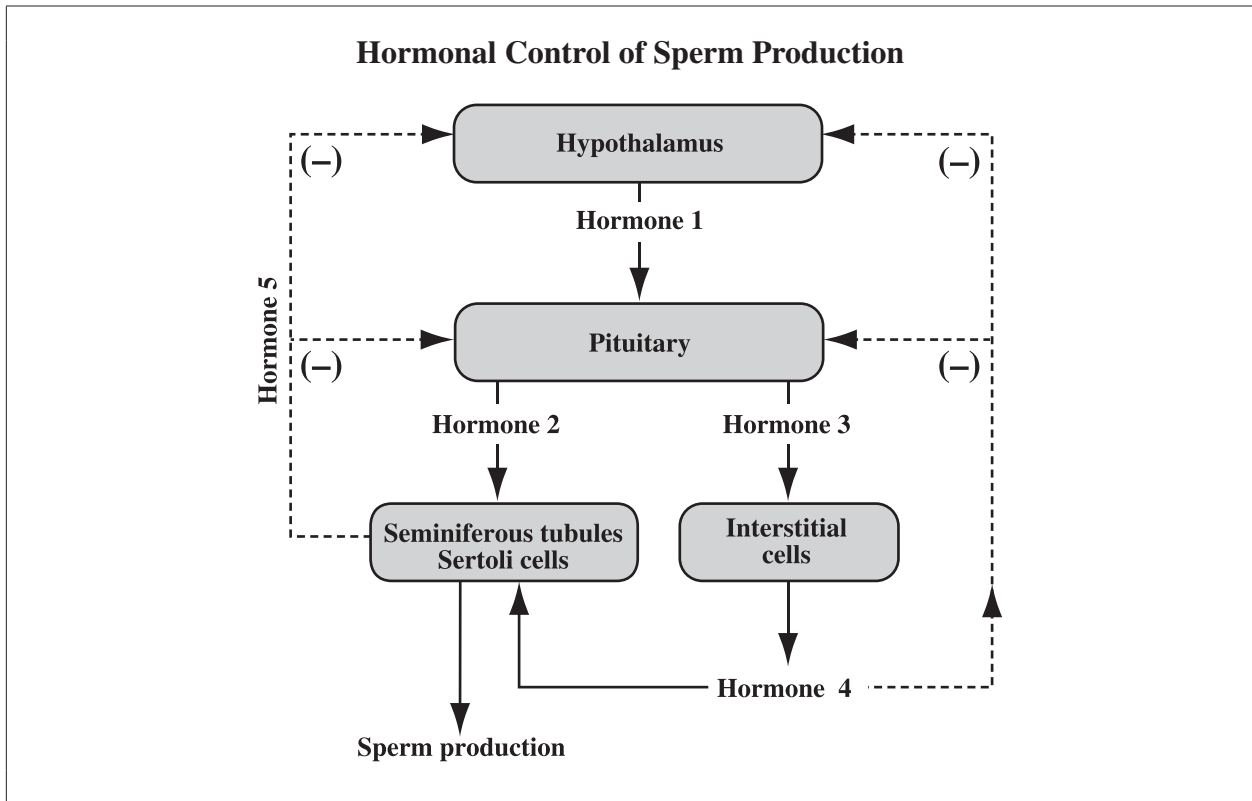

35. Which of the following rows identifies FSH, LH, and testosterone in the diagram of hormonal control of sperm production shown above?

Row	FSH	LH	Testosterone
A.	Hormone 2	Hormone 3	Hormone 4
B.	Hormone 2	Hormone 2	Hormone 4
C.	Hormone 3	Hormone 2	Hormone 5
D.	Hormone 3	Hormone 3	Hormone 5

Answer: A

Outcome: B2.1k, B2.3k, B2.3s

Cognitive level: C/A

- 36.** If a decrease in the secretion of hormone 1 caused infertility, fewer sperm would be produced because there would be
- A.** low levels of hormone 2
 - B.** low levels of hormone 3
 - C.** high levels of hormone 4
 - D.** high levels of hormone 5

Answer: A

Outcome: B2.1k, B2.3k, B2.3s

Cognitive level: C/A

Use the following information to answer question 37.

Researchers studied the effect of cocaine on blood flow in the brain and concluded that men and women react differently to the drug. Men who used cocaine had a 20% decrease in blood flow in the brain, whereas women who used cocaine showed a decreased in blood flow in the brain only during the later stages of their menstrual cycle.

37. The two hormones that **most likely** play a role in reducing the effects of cocaine on blood flow in a woman's brain are
- A. FSH and progesterone
 - B. LH and progesterone
 - C. FSH and estrogen
 - D. LH and estrogen

Answer: C

Outcome: B2.2k

Cognitive level: C/A

Use the following information to answer questions 38 and 39.

Researchers discovered that the phase of the menstrual cycle when breast cancer surgery is performed is related to the outcome of the surgery. When a breast cancer surgery is performed during a woman's luteal phase, the hormone that has the highest concentration causes the tissue surrounding the tumour to compress, making it easier to remove the tumor.

38. The days of a woman's menstrual cycle when breast cancer surgeries would be most successful, if the first day of the menstrual cycle begins with the flow phase, are days

- A. 1 to 5
- B. 6 to 13
- C. 12 to 14
- D. 15 to 28

Answer: D

Outcome: B2.2k

Cognitive level: K

39. The hormone that **most likely** contributes to the success of breast cancer tumour removal is

- A. LH
- B. FSH
- C. estrogen
- D. progesterone

Answer: D

Outcome: B2.2k, B2.1k

Cognitive level: C/A

Use the following information to answer numerical-response question 11.

Researchers discovered that during the phase of the menstrual cycle in which a woman's estrogen level is highest, her spatial skills are weakest but her motor skills and articulation skills are enhanced.

Statements Related to Women's Spatial, Motor, and Articulation Skills

- 1 During pregnancy, a woman's motor skills are enhanced.
- 2 During pregnancy, a woman's spatial skills are enhanced.
- 3 During pregnancy, a woman's articulation skills are reduced.
- 4 Around day 1 of the menstrual cycle, a woman's spatial skills are enhanced.
- 5 Around day 14 of the menstrual cycle, a woman's motor skills are enhanced.
- 6 Around day 21 of the menstrual cycle, a woman's spatial skills are enhanced.

Numerical Response

- 11.** The research described above supports the statements numbered _____, _____, and _____.

(Record all **three digits** of your answer **in any order** in the numerical-response section on the answer sheet.)

Answer: 145 (Any order)

Outcome: B2.2k, B2.3s

Cognitive level: C/A

Use the following information to answer question 40.

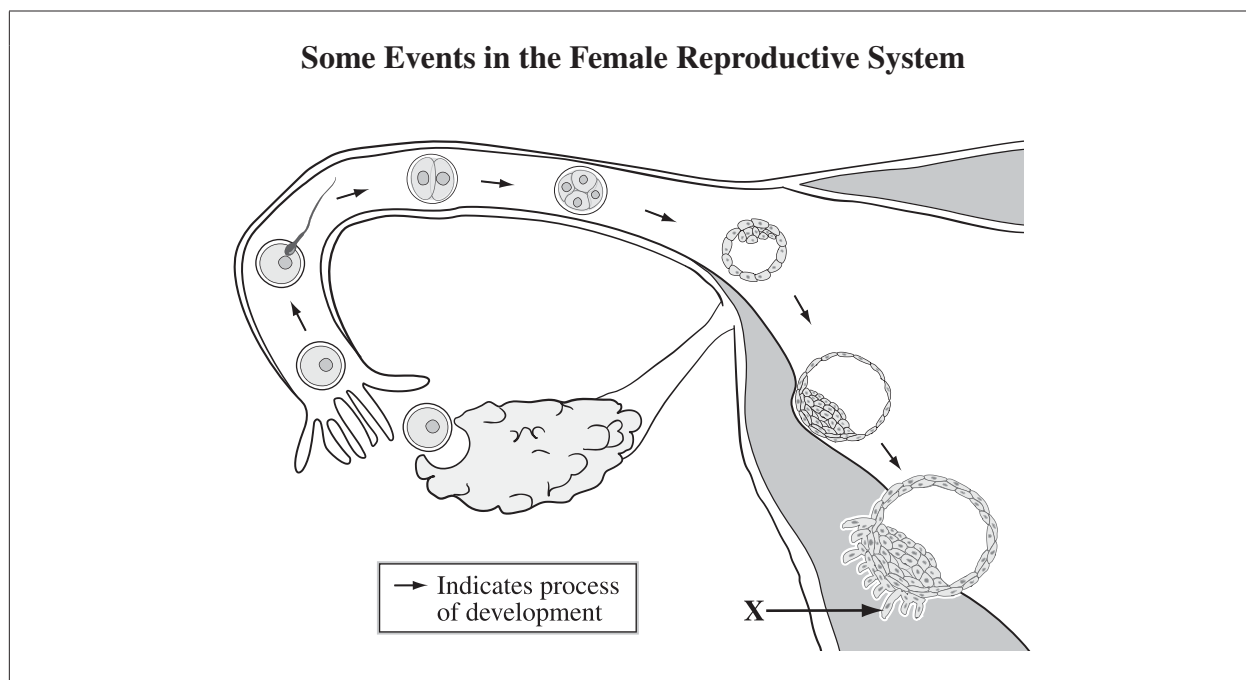

40. Which of the following rows identifies structure X in the diagram above and the structure it becomes part of?

Row	Structure X	Structure It Becomes Part of
A.	Chorion	Placenta
B.	Chorion	Amnion
C.	Placenta	Amnion
D.	Placenta	Chorion

Answer: A

Outcome: B3.1k, B3.2k, B3.3s

Cognitive level: C/A

Use the following information to answer questions 41 and 42.

A team of scientists in Japan created an artificial womb. The artificial womb was composed of a clear plastic box filled with fluid at 37° C and connected to various machines that maintained vital functions. In it they placed goat fetuses, which developed for up to three weeks. Inside the clear plastic box, each fetus was connected to a dialysis machine that removed waste and provided nutrients to the fetus.

41. Which of the following rows identifies the structure in a human female that the clear plastic box functions as and a structure that normally surrounds a fetus?

Row	Structure That the Clear Plastic Box Functions As	Structure That Normally Surrounds a Fetus
A.	Uterus	Allantois
B.	Uterus	Amniotic sac
C.	Placenta	Allantois
D.	Placenta	Amniotic sac

Answer: B

Outcome: B3.1k, B3.1sts

Cognitive level: C/A

42. The human reproductive structure that performs function analogous to that of the dialysis machine is **most likely** the
- A. yolk sac
 - B. amniotic sac
 - C. chorionic villi
 - D. umbilical cord

Answer: D

Outcome: B3.1k, B3.1sts

Cognitive level: C/A

Use the following information to answer question 43.

The drug RU-486 can be used in combination with prostaglandins to end an early pregnancy. RU-486 blocks the effects of progesterone, and the prostaglandin stimulates uterine contractions.

- 43.** The structure that deteriorates when a woman is administered RU-486 during early pregnancy is the
- A.** uterus
 - B.** endometrium
 - C.** corpus luteum
 - D.** developing follicles

Answer: B

Outcome: B3.1k, B3.1sts

Cognitive level: C/A

Use the following information to answer question 44.

A Micrograph of a Zygote

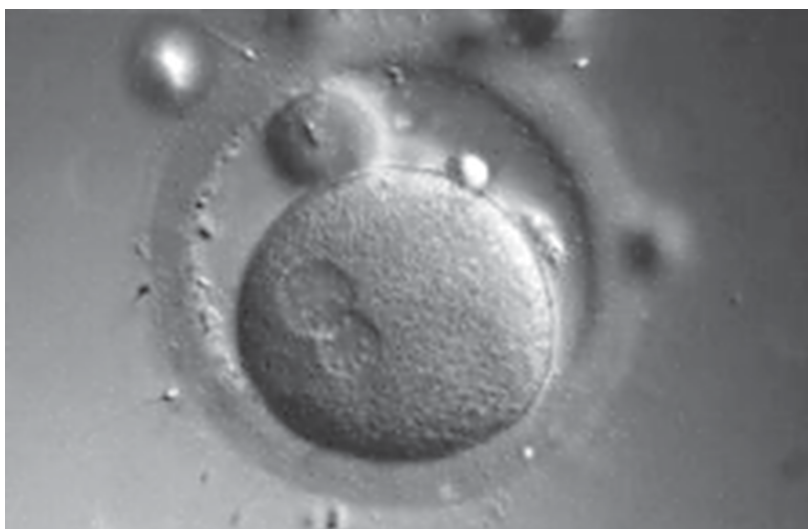

44. The female reproductive structure in which the structure depicted in the micrograph is located is the
- A. ovary
 - B. uterus
 - C. vagina
 - D. Fallopian tube

Answer: D

Outcome: B3.1k, B3.2k, B3.3s

Cognitive level: C/A

45. During the first three days of development, a human embryo obtains nutrients and energy from
- A. seminal fluid
 - B. amniotic fluid
 - C. the cytoplasm of the mother's ovum
 - D. the mitochondria of the father's sperm

Answer: C

Outcome: B3.1k

Cognitive level: K

Use the following information to answer question 46.

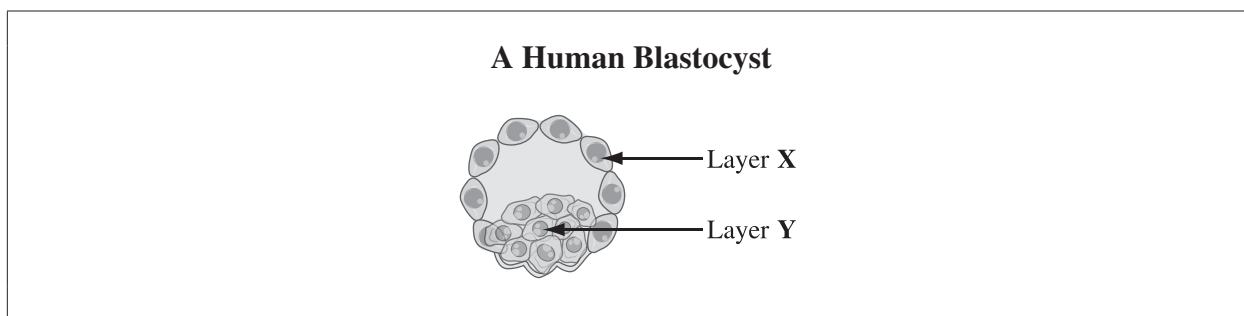

46. Using the diagram above, which of the following rows identifies the structure that develops from layer X and the structure that develops from layer Y?

Row	Structure That Develops from Layer X	Structure That Develops from Layer Y
A.	Embryo	Amnion
B.	Embryo	Chorion
C.	Chorion	Amnion
D.	Chorion	Embryo

Answer: D

Outcome: B3.1k, B3.2k, B3.3s

Cognitive level: C/A

Use the following information to answer numerical-response question 12.

Some Organs and Tissues That Develop in an Embryo

- 1 Muscle and blood
- 2 Lining of digestive tract
- 3 Brain and outer layer of skin

Numerical Response

- 12.** Match the organs and tissues numbered above with the germ layer from which they develop below.

Number: _____
Germ Layer: **Endoderm** **Mesoderm** **Ectoderm**

(Record all **three digits** of your answer in the numerical-response section on the answer sheet.)

Answer: 213
Outcome: B3.3k
Cognitive level: K

Use the following diagram to answer question 47.

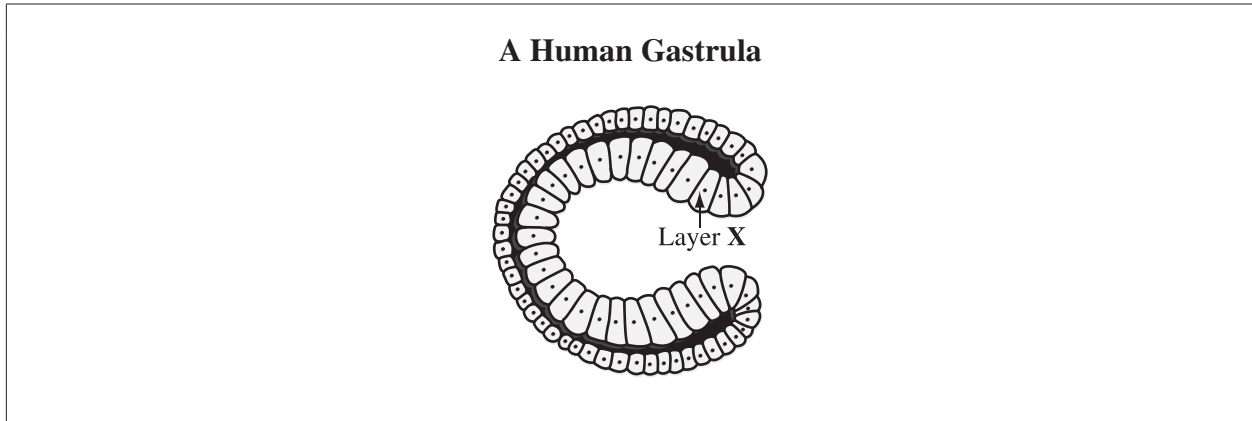

47. Which of the following rows identifies layer X as shown in the diagram above and structures that develop from this layer?

Row	Layer X	Structures That Develop from Layer X
A.	Endoderm	Skeletal, cardiac, and smooth muscles
B.	Endoderm	Lining of the digestive tract
C.	Ectoderm	Skeletal, cardiac, and smooth muscles
D.	Ectoderm	Lining of the digestive tract

Answer: B

Outcome: B3.3k, B3.2k, B3.3s

Cognitive level: C/A

Use the following information to answer question 48.

Spina bifida is a serious birth defect in which the vertebrae do not form properly around the spinal cord. A woman can greatly reduce the risk of her baby having spina bifida by supplementing her diet with a vitamin called folic acid.

48. The stage of development in which folic acid is **most** critical to embryonic or fetal development is during
- A. cleavage of the blastocyst
 - B. formation of the blastocyst
 - C. the first trimester of development
 - D. the third trimester of development

Answer: C

Outcome: B3.2k, B3.4k, B3.2s

Cognitive level: C/A

49. Which of the following events occur during the first trimester of human development?
- A. Nervous system forms, heart pumps blood, tube-like gut forms
 - B. Nervous system forms, sex differentiation occurs, fingernails develop
 - C. Heart pumps blood, tube-like gut forms, lungs become fully functional
 - D. Lungs become fully functional, heart pumps blood, sex differentiation occurs

Answer: A

Outcome: B3.2k

Cognitive level: C/A

Use the following information to answer numerical-response question 13.

A Human Embryo

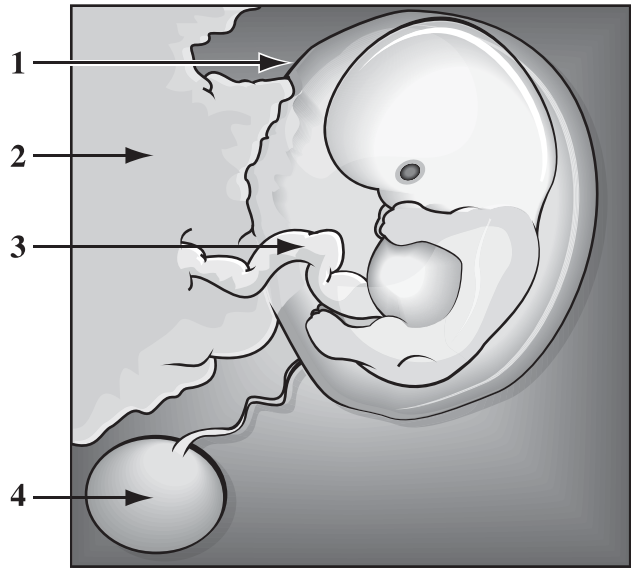

Some Functions of Embryonic Structures

- A** Provides protection
- B** Transports embryonic blood
- C** Used for nourishment in vertebrates other than mammals
- D** Site of exchange between embryonic and maternal blood

Numerical Response

13 Match each embryonic structure numbered above with the statement that represents its function below.

Number: _____
Statement: **A** **B** **C** **D**

(Record all **four digits** of your answer in the numerical-response section on the answer sheet.)

Answer: 1342
Outcome: B3.1k, B3.3s
Cognitive level: C/A

Use the following information to answer question 50.

Premature infants born at 24-weeks gestation may develop some physiological problems.

50. A reason why physiological problems may develop in infants born at 24-weeks gestation is that they
- A. have organs that are underdeveloped
 - B. have not yet begun cell specialization
 - C. depend upon amniotic fluid for oxygen
 - D. depend upon amniotic fluid for nutrients

Answer: A

Outcome: B3.2k

Cognitive level: C/A

Use the following information to answer question 51.

Research has shown that the interests and abilities of a female twin may be influenced by sharing the uterus with a male twin. In sets of non-identical twins with one female and one male, the females appear to have brain activity patterns that are more similar to males than to other females.

51. The hormone that is **most likely** responsible for influencing the development of brain activity patterns in a female who has a male twin is
- A. LH
 - B. FSH
 - C. estrogen
 - D. testosterone

Answer: D

Outcome: B3.4k, B2.1k

Cognitive level: C/A

Use the following information to answer question 52.

In the late 1950s and early 1960s, the drug thalidomide was prescribed to pregnant women to prevent morning sickness. It was later discovered that thalidomide causes birth defects, such as stunted growth of the arms and legs.

52. Which of the following rows identifies the classification of thalidomide as a factor affecting fetal development and the trimester during which exposure to thalidomide would have the **greatest** effect on a fetus?

Row	Classification	Trimester
A.	Genetic	First
B.	Genetic	Second
C.	Environmental	First
D.	Environmental	Second

Answer: C

Outcome: B3.4k, B3.2s

Cognitive level: C/A

Use the following diagram to answer question 53.

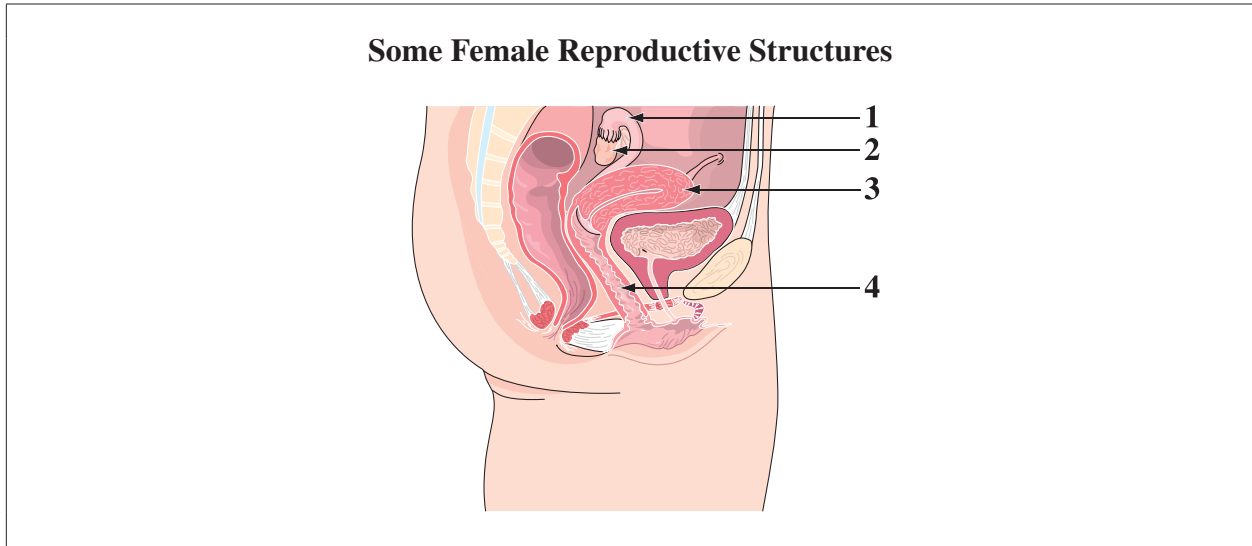

53. The female reproductive structure into which an embryo produced by in vitro fertilization is transferred is numbered

- A.** 1
- B.** 2
- C.** 3
- D.** 4

Answer: C

Outcome: B3.5k, B1.1k, B1.2s, B3.1sts

Cognitive level: K

54. To prepare a woman's uterus for the implantation of an embryo produced by in vitro fertilization, a woman can be given injections of the hormones

- A.** FSH and LH
- B.** estrogen and LH
- C.** progesterone and FSH
- D.** estrogen and progesterone

Answer: D

Outcome: B2.2k, B3.5k, B3.1sts

Cognitive level: K

55. A hormone administered to a woman following the implantation of an embryo produced by in vitro fertilization in order to maintain the pregnancy is **most likely**
- A. LH
 - B. FSH
 - C. estrogen
 - D. progesterone

Answer: D

Outcome: B3.5k, B2.2k, B3.1sts

Cognitive level: C/A

*Use the following information to answer questions 56 and 57
and numerical-response question 14.*

Scientists have developed a contraceptive ring for women. The flexible plastic ring can be folded and inserted into the vagina. Once inserted, it springs back into shape and fits around the cervix, where it releases hormones at a constant rate for three weeks. These hormones are the same as the ones found in the birth control pill.

56. The process that is **directly** inhibited by the contraceptive ring in order to prevent pregnancy is
- A. ovulation
 - B. fertilization
 - C. implantation
 - D. menstruation

Answer: A

Outcome: B3.5k, B2.2k, B3.1sts

Cognitive level: C/A

Use the following additional information to answer numerical-response question 14.

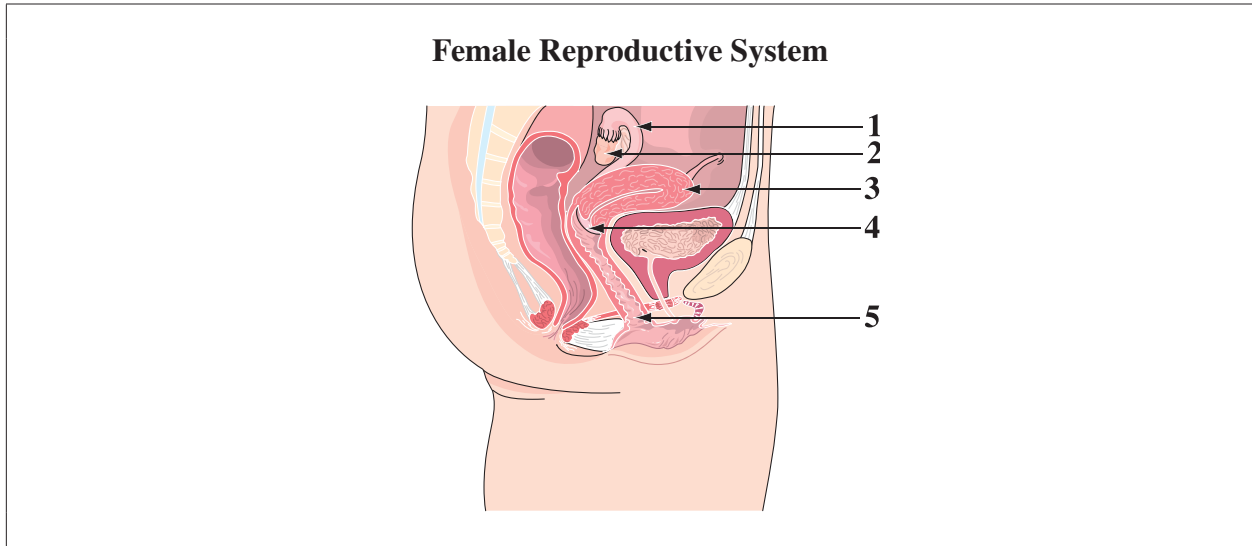

Numerical Response

14. Match three female structures numbered above with their descriptions given below.

Number:	_____	_____	_____
Description:	Site of insertion of the contraceptive ring	Site where the contraceptive ring is placed	Normal site of fertilization

(Record all **three digits** of your answer in the numerical-response boxes at the bottom of the screen.)

Answer: 541

Outcome: B3.1k, B3.5k, B1.1k, B1.2s, B3.1sts

Cognitive level: C/A

57. Which of the following rows identifies the hormones released by the contraceptive ring and describes their expected effect on the secretion of reproductive hormones in a woman?

Row	Hormones	Expected Effect
A.	FSH and LH	Stimulates estrogen and progesterone
B.	FSH and LH	Inhibits estrogen and progesterone
C.	Estrogen and progesterone	Stimulates FSH and LH
D.	Estrogen and progesterone	Inhibits FSH and LH

Answer: D

Outcome: B3.5k, B2.2k, B3.1sts

Cognitive level: C/A

Unit C

- 58.** The chromosome content of a polar body that forms during the development of a mature ovum is
- A.** diploid, and it contains two sex chromosomes
 - B.** diploid, and it contains a single sex chromosome
 - C.** haploid, and it contains two sex chromosomes
 - D.** haploid, and it contains a single sex chromosome

Answer: D

Outcome: C1.3k, C1.1k

Cognitive level: K

- 59.** The process that occurs to form an eight-cell embryo from a zygote is
- A.** mitosis of diploid cells
 - B.** mitosis of haploid cells
 - C.** meiosis of diploid cells
 - D.** meiosis of haploid cells

Answer: A

Outcome: C1.1k, C1.4k

Cognitive level: K

Use the following information to answer questions 60 and 61.

Atlantic salmon are raised commercially in fish cages on the Pacific coast of Canada and have often been genetically modified. If some of the Atlantic salmon escape from their cages, they could mate with native Pacific salmon stocks. If this happens, there is concern that the original native salmon population would decrease.

One way to prevent the disappearance of native salmon stocks is to reverse the sex of genetically modified female salmon. Sex-reversal of a female salmon produces a salmon with female sex chromosomes and a male reproductive tract. Sex-reversed females can be used to produce sperm with only X chromosomes. These sperm fertilize eggs from non-genetically modified females, and the fertilized eggs are then treated with heat or pressure shock to induce triploidy ($3n$). This creates a population of sterile female fish for commercial markets. Sex chromosomes in salmon are similar to sex chromosomes in humans.

60. The sex chromosomes of the sterile female fish described above are

- A. XO
- B. XX
- C. XXY
- D. XXX

Answer: D

Outcome: C1.1k, C2.5k, C1.1sts

Cognitive level: C/A

Use the following additional information to answer question 61.

Some Atlantic salmon have been genetically modified by inserting a growth hormone gene from native Pacific Chinook salmon into their genome, thereby allowing the Atlantic salmon to grow to adult size more quickly.

61. A cellular event that must occur in order for genetically modified Atlantic salmon to grow to adult size more quickly is

- A. translation of the growth hormone gene in the nuclei of cells
- B. replication of the growth hormone gene in the nuclei of cells
- C. translation of mRNA of the growth hormone gene in the cytoplasm of cells
- D. replication of mRNA of the growth hormone gene in the cytoplasm of cells

Answer: C

Outcome: C3.3k, C3.2k, C3.2sts

Cognitive level: C/A

- 62.** The cellular content of a human cell that causes the male reproductive system to develop is the
- A.** Y chromosome, because it inhibits estrogen secretion by the gonads
 - B.** Y chromosome, because it stimulates testosterone secretion by the gonads
 - C.** single X chromosome, because it inhibits estrogen secretion by the gonads
 - D.** single X chromosome, because it stimulates testosterone secretion by the gonads

Answer: B

Outcome: C2.5k, B1.4k

Cognitive level: C/A

Use the following information to answer question 63.

Intracytoplasmic sperm injection (ICSI) is a reproductive technology in which a sperm is injected directly into an ovum.

- 63.** Which of the following outcomes would be expected if, during the ICSI process, more than one sperm were injected into an ovum?
- A.** Fraternal twins would be formed.
 - B.** Identical twins would be formed.
 - C.** The zygote would develop into a male child since more male chromosomes would be present.
 - D.** The zygote would likely not develop because more than a diploid set of chromosomes would be present.

Answer: D

Outcome: C1.1k, C1.6k, B3.5k, B3.1sts, B1.3s

Cognitive level: C/A

64. The mitotic phase that occurs immediately before cytokinesis in most animal cells is
- A. anaphase
 - B. prophase
 - C. telophase
 - D. metaphase

Answer: C

Outcome: C1.2k

Cognitive level: K

Use the following information to answer numerical-response question 15.

Some Events That Occur at Various Stages of Oogenesis

- 1 DNA replicates
- 2 Centromeres split and sister chromatids separate
- 3 Pairs of replicated chromosomes align at the equator of the cell
- 4 Homologous chromosomes separate and members of each chromosome pair move to opposite poles

Numerical Response

15. Match each of the events that occur in oogenesis numbered above with the stage at which it occurs below.

Number: _____
Stage: **Interphase** **Metaphase I** **Anaphase I** **Anaphase II**

(Record all **four digits** of your answer in the numerical-response section on the answer sheet.)

Answer: 1342

Outcome: C1.3k

Cognitive level: K

Use the following information to answer question 65.

Patau syndrome (trisomy 13) and Edward syndrome (trisomy 18) are classified as autosomal trisomies. In order to identify autosomal trisomies, a procedure known as chorionic villus sampling can be used to obtain cells from an embryo that are then used to create a karyotype like the one shown below.



65. Which of the following rows identifies the sex of the embryo and the name of the autosomal trisomy identified in the karyotype shown above?

Row	Sex	Autosomal Trisomy
A.	Female	Patau syndrome
B.	Female	Edward syndrome
C.	Male	Patau syndrome
D.	Male	Edward syndrome

Answer: D

Outcome: C1.1k, C2.5k, C1.3s

Cognitive level: C/A

Use the following information to answer question 66.

Geneticists have discovered that some species have sex chromosomes that are virtually homologous except for a sex-determining region on one of the chromosomes. Other species, including humans, have very small portions of the X and Y chromosomes that carry similar genes. Furthermore, in humans, it is the Y chromosome that contains a dominant sex-determining allele.

66. The small homologous portions of human X and Y chromosomes are most important in
- A. mitosis because the chromosomes pair up and segregate
 - B. meiosis because the chromosomes pair up and segregate
 - C. mitosis because the chromosomes pair up but do not segregate
 - D. meiosis because the chromosomes pair up but do not segregate

Answer: B

Outcome: C1.3k, C1.4k

Cognitive level: C/A

Use the following information to answer question 67.

Whiptail lizards can reproduce by parthenogenesis. Parthenogenesis is a type of reproduction in which females produce offspring from unfertilized eggs that have undergone chromosome doubling after meiosis. The chromosome arrangement in whiptail lizards is similar to that in humans.

67. The somatic cells of offspring produced from a whiptail lizard's unfertilized eggs would have a ploidy of
- A. n
 - B. $2n$
 - C. $4n$
 - D. $n + 2$

Answer: B

Outcome: C1.1k, C1.7k

Cognitive level: HMA

Use the following diagram to answer questions 68 and 69.

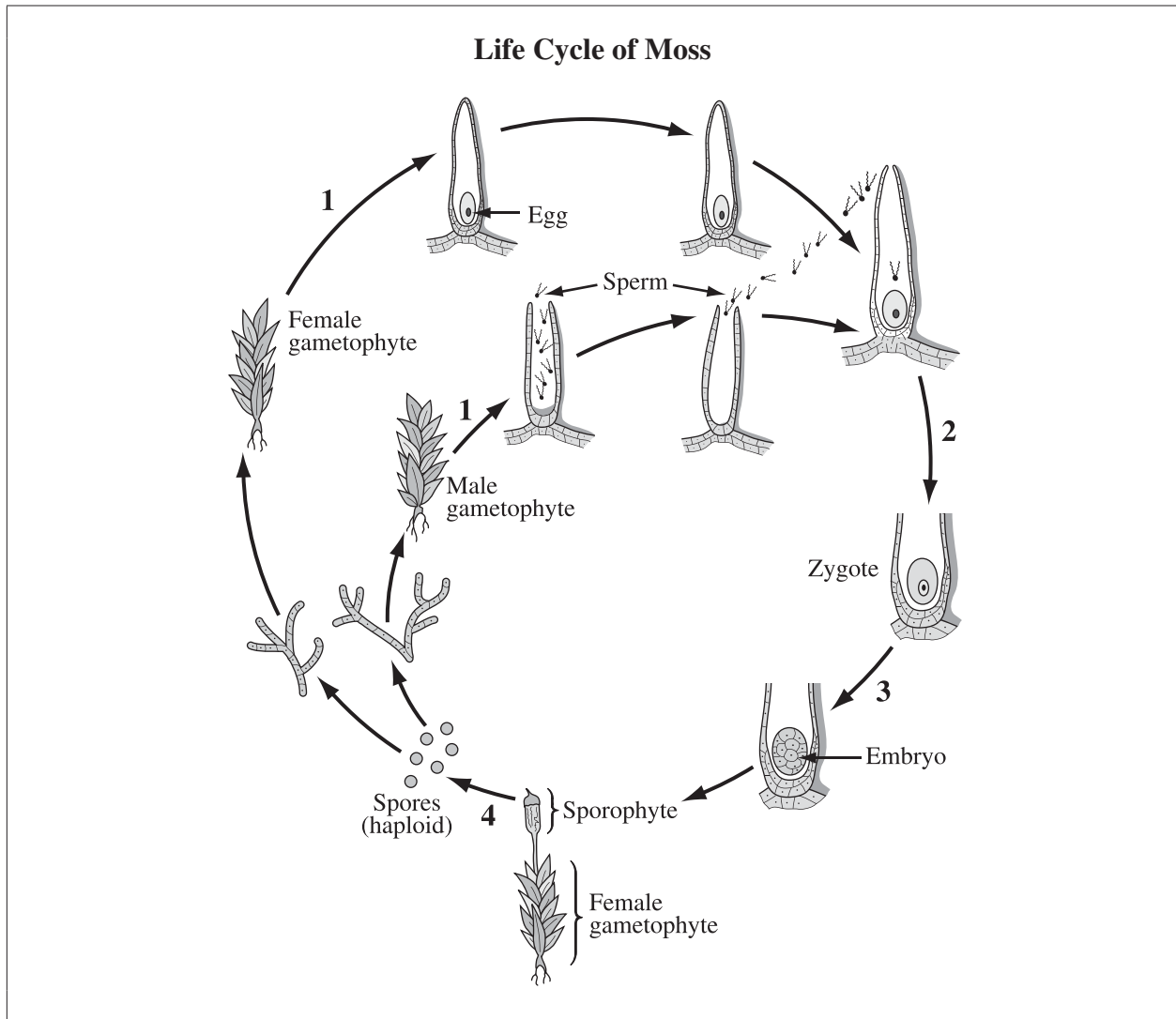

68. Two processes in the life cycle of moss that contribute to increased genetic variation are

- A. 1 and 2
- B. 2 and 3
- C. 2 and 4
- D. 3 and 4

Answer: C

Outcome: C1.4k, C1.7k, C1.2s

Cognitive level: C/A

69. In moss plants, spores and gametes are similar in that both are

- A.** diploid cells
- B.** haploid cells
- C.** produced by mitosis
- D.** produced by meiosis

Answer: B

Outcome: C1.4k, C1.7k, C1.2s

Cognitive level: C/A

Use the following information to answer question 70.

An organism is heterozygous for two genes, each of which are located on a different chromosome.

70. The number of different combinations of alleles that can form from these two genes in the organism's gametes is

- A.** 1
- B.** 2
- C.** 4
- D.** 8

Answer: C

Outcome: C2.1k

Cognitive level: C/A

Use the following information to answer questions 71 and 72.

A form of abnormally aggressive behaviour can be caused by a mutation in a segment of DNA that codes for an enzyme that breaks down a neurotransmitter in the brain. Females who are heterozygous for the mutation do not have an aggressive phenotype.

71. The law of genetics, as investigated by Mendel, that is responsible for heterozygous females who **do not** express the mutation is
- A. sex linkage
 - B. dominance
 - C. segregation
 - D. independent assortment

Answer: B

Outcome: C2.1k

Cognitive level: C/A

Use the following additional information to answer question 72.

The mutation associated with abnormally aggressive behaviour results in the normal codon for glutamine becoming a stop codon.

72. Which of the following mutations would change the codon for glutamine into a stop codon?
- A. CAA to ATT
 - B. GAA to UAA
 - C. GAG to UAG
 - D. CAG to UAG

Answer: D

Outcome: C3.3k, C3.6k, C3.2s

Cognitive level: C/A

Use the following information to answer question 73.

Tay-Sachs disease is a genetic disorder that occurs in 1 in every 360 000 children. Children who are homozygous for Tay-Sachs disease die at a young age. Genetic screening can be done to determine whether a person is a carrier of the Tay-Sachs allele.

73. The pattern of inheritance exemplified by Tay-Sachs disease is

- A.** X-linked recessive
- B.** X-linked dominant
- C.** autosomal recessive
- D.** autosomal dominant

Answer: C

Outcome: C2.2k, C2.5k, C2.3s

Cognitive level: C/A

Use the following information to answer numerical-response question 16.

The coat colour of Labrador retrievers is determined by a pair of genes. One gene codes for coat colour and the second gene codes for the expression of the colour.

In the gene that codes for coat colour, the black allele, B , is dominant to the brown allele, b . In the gene that codes for the expression of colour, the alleles E and e affect the expression of the coat colour: the homozygous recessive condition, ee , prevents the expression of black or brown and produces a pup with a yellow coat.

Genotype	Phenotype
$B_E_$	Black
$bbE_$	Brown
$__ee$	Yellow

Numerical Response

16. If two Labrador retrievers with the genotype $BbEe$ mated and produced offspring, what phenotypic ratio would be expected in their offspring?

Ratio: _____ : _____ : _____
Phenotype: **Black** **Brown** **Yellow**

(Record all **three digits** of your answer in the numerical-response section on the answer sheet.)

Answer: 934

Outcome: C2.2k, C2.3s

Cognitive level: C/A

Use the following information to answer question 74.

A particular mutation in mitochondrial DNA causes Kearns–Sayre syndrome (KSS). A large sample of different types of somatic cells was removed from a man with KSS. The cells were tested and the researchers determined that he had the mutation. The man’s mother was also tested, but her results did not show that she had the mutation.

74. A reasonable hypothesis to explain the results described above is that the mutation in the mitochondrial DNA that caused KSS in the man first occurred in
- A. the mother’s ovum
 - B. the man’s sperm cells
 - C. one of the man’s somatic cells early in development
 - D. one of the mother’s somatic cells early in development

Answer: C

Outcome: C3.7k, C3.2sts

Cognitive level: C/A

75. Which of the following rows describes the cellular contributions made by sperm and ovum to the formation of a zygote?

Row	Sperm’s Contribution to Zygote	Ovum’s Contribution to Zygote
A.	Nuclear contents only	Both nuclear and cytoplasmic contents
B.	Both nuclear and cytoplasmic contents	Nuclear contents only
C.	Neither nuclear nor cytoplasmic contents	Both nuclear and cytoplasmic contents
D.	Both nuclear and cytoplasmic contents	Neither nuclear nor cytoplasmic contents

Answer: A

Outcome: C3.1k, C3.7k

Cognitive level: K

Use the following information to answer question 76.

Researchers have identified a mutation in a gene called *WNT2* that may be associated with development of speech and language problems in people with autism. A second gene, called *RELN*, has also been associated with a genetic risk for the development of autism.

76. Which of the following statements describes a likely relationship between the *WNT2* and *RELN* genes?
- A. They produce similar proteins.
 - B. They are exchanged during meiosis.
 - C. They have similar nucleotide sequences.
 - D. They are located on the same chromosome.

Answer: D

Outcome: C2.3k

Cognitive level: C/A

Use the following information to answer numerical-response question 17 and question 77.

The map distances of four genes found on human chromosome 6 are shown below.

Genes	Map Distance (in map units)
1 and 2	21
1 and 3	12
2 and 3	9
2 and 4	19.5

Legend

- 1** Diabetes mellitus
- 2** Ragweed sensitivity
- 3** Rh blood group
- 4** Ovarian cancer

Numerical Response

- 17.** The order in which the four genes listed above are located on chromosome 6 is _____, _____, _____, and _____.

(Record all **four digits** of your answer in the numerical-response section on the answer sheet.)

Answer: 1432 or 2341

Outcome: C2.3k, C2.3s

Cognitive level: C/A

- 77.** The cross-over frequency between the diabetes mellitus gene and the ovarian cancer gene is

- A.** 1.5%
- B.** 10.5%
- C.** 15.0%
- D.** 22.5%

Answer: A

Outcome: C2.3k, C2.3s

Cognitive level: C/A

Use the following information to answer question 78 and numerical-response question 18.

A dominant allele causes the formation of faulty tooth enamel. The allele, which is carried on the X chromosome, causes either very thin or very hard enamel.

Pedigree Illustrating the Inheritance of Faulty Tooth Enamel

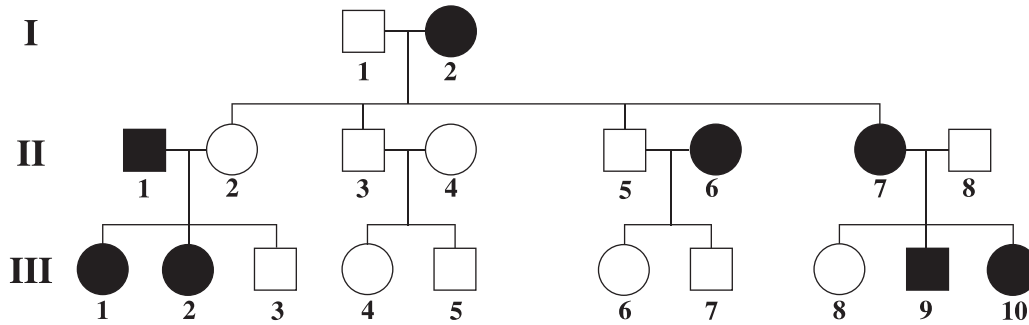

78. Which of the following rows **best** identifies the genotypes of individuals **II-6** and **III-7**?

Row	II-6	III-7
A.	$X^E X^E$	$X^E Y$
B.	$X^E X^e$	$X^e Y$
C.	$X^e X^e$	$X^E Y$
D.	$X^E X^E$	$X^e Y$

Answer: B

Outcome: C2.5k, C2.3s

Cognitive level: C/A

Use the following additional information to answer numerical-response question 18.

A woman who is heterozygous for faulty tooth enamel has a child with a man who does not have faulty tooth enamel.

Numerical Response

18. What is the probability that this child will be a boy who does **not** have faulty tooth enamel?

Answer: _____

(Record your answer as a value between 0 and 1 rounded to two decimal places in the numerical-response section on the answer sheet.)

Answer: 0.25

Outcome: C2.2k, C2.5k, C2.3s

Cognitive level: C/A

Use the following information to answer numerical-response question 19.

In 1953, Watson and Crick developed a model of the structure of DNA. They used a trial and error approach which involved compiling discoveries made by other scientists until their model was complete.

The following statements describe some discoveries about DNA made before 1953.

- 1 Chromosomes and genes are composed of DNA.
- 2 DNA is found mainly in the nucleus of eukaryotic cells.
- 3 X-ray diffraction of the DNA molecule shows that it is a helix.
- 4 All of the diploid cells in a particular organism contain the same amount of DNA.
- 5 The DNA molecule is composed of deoxyribose sugar, phosphate, and four different nitrogen bases.
- 6 Analyses of proportions of the nitrogen bases in DNA suggest that thymine pairs with adenine and guanine pairs with cytosine.

Numerical Response

19. Three discoveries that would have provided essential clues to Watson and Crick as they developed the model of DNA are given in the statements numbered _____, _____, and _____.

(Record all **three digits** of your answer **in any order** in the numerical-response section on the answer sheet.)

Answer: 356 (Any order)

Outcome: C3.1k

Cognitive level: C/A

79. If guanine and cytosine make up 56% of the nitrogen bases present in a DNA molecule, what percentage of the DNA's nitrogen bases are made up of adenine?

- A. 22%
- B. 25%
- C. 28%
- D. 44%

Answer: A

Outcome: C3.2k, C3.2s

Cognitive level: C/A

80. Which of the following rows describes the components of a DNA molecule, the backbone of DNA, and the molecules that join the two strands of DNA?

Row	Components	Backbone	Molecules That Join the two Strands of DNA
A.	Amino acids, sugars, and bases	Sugars and bases	Amino acids
B.	Amino acids, sugars, and bases	Sugars and amino acids	Bases
C.	Phosphates, sugars, and bases	Sugars and bases	Amino acids
D.	Phosphates, sugars, and bases	Sugars and phosphates	Bases

Answer: D

Outcome: C3.2k, C3.2s

Cognitive level: K

Use the following information to answer question 81.

During the development of a fruit fly, a protein called bicoid initiates transcription in order to control development of the embryo. Transcription in fruit flies is similar to that in humans.

81. To initiate transcription, the molecule that bicoid binds to is
- A. DNA, which causes DNA to copy itself
 - B. tRNA, which causes tRNA to join amino acids
 - C. mRNA, which causes mRNA to start protein synthesis
 - D. DNA, which causes DNA to produce mRNA for a particular gene

Answer: D

Outcome: C3.3k

Cognitive level: C/A

Use the following information to answer questions 82 and 83.

Scientists can genetically engineer plants to produce particular proteins. To do this, scientists select a specific gene that codes for a specific protein; for example, the gene that codes for a viral protein. This gene is modified by adding two DNA sequences: a DNA sequence that will signal root cells in plants to secrete the viral protein and a DNA sequence that activates the gene in root cells.

This modified gene is then inserted into plant cells. When these plants are grown hydroponically in a nutrient solution rather than in soil, scientists can easily collect the released proteins from the solution.

- 82.** Which of the following statements best explains the results of the genetic engineering procedure described above?
- A.** Some genes are recessive.
 - B.** Genes can be turned on and off.
 - C.** All DNA codes for the production of proteins.
 - D.** All cells that have the same DNA produce the same proteins.

Answer: B

Outcome: C3.5k, C3.2sts

Cognitive level: C/A

- 83.** DNA that codes for a viral protein could be present in every cell of a plant if the DNA was inserted into a
- A.** plant zygote
 - B.** plant root cell
 - C.** plant somatic cell
 - D.** plant's transport system

Answer: A

Outcome: C3.5k, C3.2sts

Cognitive level: C/A

Use the following information to answer numerical-response question 20.

Some Processes in Protein Synthesis

- 1 mRNA exits the nucleus.
- 2 Amino acids are joined to form a polypeptide.
- 3 tRNA carrying a specific amino acid binds to mRNA.
- 4 mRNA attaches to nucleotides on a specific section of exposed DNA.

Numerical Response

- 20.** The order in which the processes in protein synthesis in plant root cells listed above occur is _____, _____, _____, and _____.

(Record all **four digits** of your answer in the numerical-response section on the answer sheet.)

Answer: 4132

Outcome: C3.3k, C3.2k

Cognitive level: K

Use the following information to answer questions 84 and 85.

The American Wirehair cat breed was first observed in a litter of cats on a farm in New York in 1966. Two cats that did not have wire-like hair produced a litter of kittens, one of which had whiskers and coat hair that were wire-like. The allele for this wire-like hair is dominant to the allele for normal hair.

84. The wirehaired kitten produced in the litter described above was **most likely** the result of
- A. selective breeding
 - B. a spontaneous mutation
 - C. mating two heterozygous cats
 - D. mating a homozygous recessive cat with a heterozygous cat

Answer: B

Outcome: C3.6k, C3.1sts

Cognitive level: C/A

Use the following additional information to answer question 85.

In order to select breeding stock for the wirehair trait, cat breeders try to determine which of the offspring are homozygous for the wirehair trait.

85. To select breeding stock for the wirehair trait, a cross should be performed between a potential breeding cat and a cat
- A. with the wirehair phenotype
 - B. with a heterozygous genotype
 - C. without the wirehair phenotype
 - D. without a homozygous dominant genotype

Answer: C

Outcome: C2.2k

Cognitive level: C/A

Use the following information to answer question 86.

In a simulated forensic investigation, five DNA samples were prepared for gel electrophoresis. Four of the samples were obtained from volunteer suspects (W, X, Y, and Z), and the fifth sample was taken from the simulated crime scene.

The DNA samples were treated with restriction enzymes and placed into wells in a gel with electrodes at each end. When electricity was applied to the gel, the DNA fragments migrated toward the opposite end of the gel. The smaller DNA fragments move further from the wells than the larger DNA fragments.

Electrophoresis Gel from a Simulated Forensic Investigation

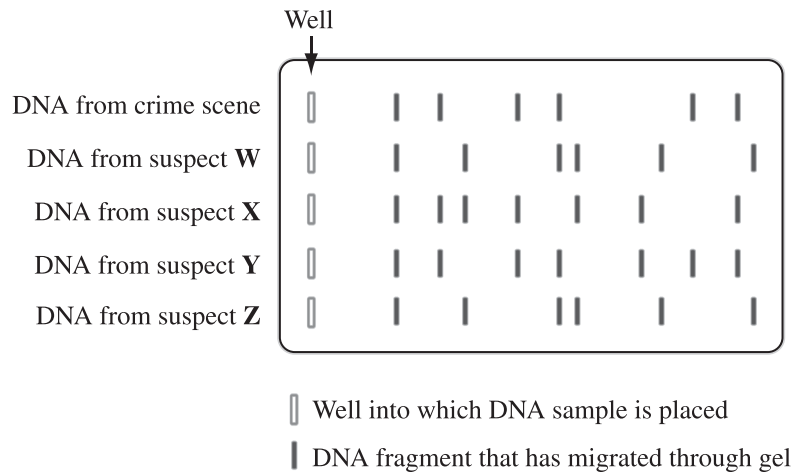

86. Based on the evidence shown in the illustration of an electrophoresis gel above, which of the following statements is **most** probable?
- A. Suspect W and suspect Y are closely related.
 - B. Suspect W and suspect Z are identical twins.
 - C. Suspect X left biological evidence at the crime scene.
 - D. Suspect Y left biological evidence at the crime scene.

Answer: B

Outcome: C3.4k, C3.2s, C3.3s, C3.2sts

Cognitive level: C/A

Use the following information to answer question 87.

A researcher studied DNA that was transmitted only by males in order to trace back humans to a common male ancestor who lived 188 000 years ago.

- 87.** The part of the human cell that the researcher would have studied in order to trace the DNA to a common male ancestor is
- A.** the X chromosome
 - B.** the Y chromosome
 - C.** RNA in the ribosomes
 - D.** DNA in the mitochondrion

Answer: B

Outcome: C3.7k, C3.3s, B1.4k

Cognitive level: C/A

Use the following information to answer question 88.

In a study, a team of scientists collected samples of mitochondrial DNA from people living on different continents and compared the number of mitochondrial DNA mutations among these samples. They used this data as evidence to determine the order in which Earth's continents were populated.

- 88.** The manipulated variable in the study described above is the
- A.** amount of mitochondrial DNA tested
 - B.** order in which the continents became populated
 - C.** amount of variation in mitochondrial DNA base sequences
 - D.** geographic location of subjects whose sample of mitochondrial DNA was tested

Answer: D

Outcome: C3.7k

Cognitive level: C/A

Unit D

Use the following information to answer question 89.

Cystic fibrosis (CF) is one of the most common autosomal recessive disorders. 1 in 2 500 Caucasian newborns have CF.

89. The frequency of the recessive allele for CF in the Caucasian population is

- A.** 0.02
- B.** 0.04
- C.** 0.25
- D.** 0.33

Answer: A

Outcome: D1.3k, D1.3s

Cognitive level: C/A

Use the following information to answer numerical-response question 21.

Genetically modified Atlantic salmon have been developed for commercial use. These salmon are raised in fish cages on the Pacific coast of Canada. If some of these fish were to escape these cages, mating could occur with the native Pacific salmon. This could lead to a decline in the native Pacific salmon population.

Some Facts About Genetically Modified Fish

- 1 Juvenile genetically modified fish have bright coloration.
- 2 Genetically modified fish are slower swimmers than native fish.
- 3 Sterilization techniques for genetically modified fish are not 100% reliable.
- 4 Genetically modified fish eat more than native fish and deplete food sources.
- 5 Genetically modified fish reach sexual maturity at a younger age than native fish.
- 6 Genetically modified fish have a mating advantage over native fish as a result of their larger size.
- 7 Genetically modified fish grow larger in laboratory conditions than in the natural environment.
- 8 Genetically modified fish are 30% more likely to die before reaching sexual maturity than native fish.

Numerical Response

- 21.** Four statements that are **most likely** to raise concerns that the native Pacific salmon population might decline if genetically modified salmon escaped from their cages are _____, _____, _____, and _____.

(Record all **four digits** of your answer **in any order** in the numerical-response section on the answer sheet.)

Answer: 3456 (Any order)

Outcome: D1.2k, D1.1sts

Cognitive level: C/A

Use the following information to answer question 90.

Large fishing vessels called trawlers use nets that are dragged along the sea floor and often have catastrophic effects on the sea floor habitat. Prohibiting commercial fishing by trawlers could save not only the fish species targeted by the fishing vessels, but also many other marine species.

90. The process by which the recovery of the sea floor habitat will occur after trawlers have been prohibited is called
- A. primary succession
 - B. secondary succession
 - C. the development of a climax community
 - D. the development of a pioneer community

Answer: B

Outcome: D2.3k, D2.1sts

Cognitive level: C/A

Use the following information to answer question 91.

In his book *On the Origin of Species*, Charles Darwin wrote:

As more individuals are produced than can possibly survive, there must in every case be a struggle for existence, either one individual with another of the same species, or with the individuals of distinct species, or with the physical conditions of life.

91. Darwin's description of the struggle for existence among organisms is given the term
- A. predation
 - B. mutualism
 - C. competition
 - D. commensalism

Answer: C

Outcome: D1.2k, D2.1k, D2.3s

Cognitive level: C/A

Use the following information to answer numerical-response question 22.

Hereditary deafness is an autosomal recessive disorder that occurs in 30% of Dalmatian dogs.

Numerical Response

22. What is the frequency of the allele that causes hereditary deafness in the Dalmatian dogs?

Answer: _____

(Record your answer as a value between 0 and 1 rounded to two decimal places in the numerical-response section on the answer sheet.)

Answer: 0.55

Outcome: D1.3k, D1.3s

Cognitive level: C/A

Use the following information to answer question 92.

The breeding of purebred dogs for certain characteristics related to appearance is often blamed for a large number of genetic disorders in these animals.

92. Genetic disorders in purebred dogs are **most likely** the result of

- A. natural selection
- B. nonrandom mating
- C. the founder effect
- D. high rates of mutation

Answer: B

Outcome: D1.2k

Cognitive level: C/A

Use the following information to answer question 93.

Mites are small arachnids that can live in the trachea of a bee and they obtain nutrients from bee tissue. Beekeepers worry when mite populations reach numbers that have the potential to destroy entire colonies of bees.

93. The relationship between bees and mites is **best** described as

- A. parasitism
- B. commensalism
- C. interspecific competition
- D. intraspecific competition

Answer: A

Outcome: D2.1k, D2.3s

Cognitive level: C/A

Use the following information to answer questions 94 to 96 and numerical-response question 23.

Bighorn sheep usually live on remote, rocky cliffs in the mountains. In the winter, they graze in lower mountain pastures, and then they move to higher alpine ranges in the spring. They are able to escape predators such as mountain lions and wolves because of their ability to climb and jump in their rocky habitat.

94. The relationship between mountain lions and wolves is one of

- A. mutualism
- B. commensalism
- C. intraspecific competition
- D. interspecific competition

Answer: D

Outcome: D2.1k, D2.3s

Cognitive level: C/A

Use the following additional information to answer question 95.

Female bighorn sheep typically give birth to a single lamb after a six-month gestation. Within a day, the lamb can run and climb and follow its mother along mountain ledges.

95. Which of the following rows describes the reproductive strategy of bighorn sheep and provides justification for this classification of the strategy?

Row	Reproductive Strategy	Justification
A.	<i>K</i> -selected	Long period of gestation, only one offspring produced
B.	<i>K</i> -selected	Short period of gestation, offspring develops quickly
C.	<i>r</i> -selected	Long period of gestation, only one offspring produced
D.	<i>r</i> -selected	Short period of gestation, offspring develops quickly

Answer: A

Outcome: D3.4k

Cognitive level: C/A

Use the following additional information to answer numerical-response question 23 and question 96.

Between 1960 and 2002, the bighorn sheep population of New Mexico went from approximately 450 sheep to 130 sheep.

Numerical Response

23. What was the growth rate of the bighorn sheep population between 1960 and 2002?

Answer: – _____ **sheep/year**

(Record your answer as a value rounded to two decimal places in the numerical-response section on the answer sheet.)

Answer: 7.62

Outcome: D3.2k, D3.3s

Cognitive level: C/A

Use the following additional information to answer question 96.

State officials in New Mexico blame the decline in the bighorn sheep population on predation by mountain lions and have responded by increasing the number of lions that hunters are permitted to hunt each year.

- 96.** Which of the following conditions required for Hardy–Weinberg equilibrium will initially be affected by increased hunting?
- A.** No mutations
 - B.** No genetic drift
 - C.** Random mating
 - D.** Large population size

Answer: D

Outcome: D1.1k, D1.2k

Cognitive level: C/A

Use the following information to answer questions 97 and 98.

The organ pipe cactus has flowers that open at night. Bats and insects pollinate these flowers. The fruit of the cactus is eaten by birds and small mammals, which scatter and distribute the fruit seeds. The coyote, in turn, feeds on the birds and small mammals.

97. Which of the following rows describes the relationship between the organ pipe cactus and insects and between the organ pipe cactus and small mammals?

Row	Relationship Between Cactus and Insects	Relationship Between Cactus and Small Mammals
A.	Predation	Predation
B.	Predation	Mutualism
C.	Mutualism	Predation
D.	Mutualism	Mutualism

Answer: D

Outcome: D2.1k, D2.3s

Cognitive level: C/A

Use the following additional information to answer question 98.

The organ pipe cactus is a desert plant species. An adaptation of the organ pipe cactus to the desert climate is that it opens its flower petals at night and closes them during the day to avoid dehydration during the heat of the day.

98. Which of the following statements **best** explains the development of the adaptation of the organ pipe cactus?
- A. High desert temperatures increase mutation rates in the flower petals.
 - B. Organ pipe cacti with flowers that open at night have increased reproductive success.
 - C. The intense heat of the desert, which destroys all flower petals that open during the day, causes the cactus to open its flower petals at night.
 - D. The pipe organ cactus reacts to extreme heat, which causes it to close its flower petals during the day, and gradually develops the behaviour of opening its flower petals at night.

Answer: B

Outcome: D1.4k

Cognitive level: C/A

Use the following information to answer numerical-response question 24 and question 99.

The burrowing owl is an endangered species in Canada's western provinces. Research data collected in Saskatchewan's Burrowing Owl Recovery Project indicate that the population has declined by 20% per year between 1991 and 1996. In 1996, a population estimate showed that there were 1 600 burrowing owls in the population. If the population continued to decline at the rate it did between 1991 and 1996, the burrowing owl population in 1998 was expected to decrease to 1 024 burrowing owls.

Numerical Response

- 24.** What was the per capita growth rate of the burrowing owl population from 1996 to 1998?

Answer: – _____

(Record your answer as a value between 0 and 1 rounded to two decimal places in the numerical-response section on the answer sheet.)

Answer: 0.36

Outcome: D3.2k, D3.3s

Cognitive level: C/A

Use the following additional information to answer question 99.

The burrowing owl habitat is open prairie grass. The owls live in ground squirrel holes that have been enlarged by badgers. The young owls are cared for by both parents, who feed them a diet consisting of mice, moles, and insects. Other prairie predators such as the rattlesnake and sparrow hawk also rely upon these same food sources.

- 99.** Which of the following rows describes the relationship between a burrowing owl and a badger and the relationship between a sparrow hawk and a burrowing owl?

Row	Relationship Between Burrowing Owl and a Badger	Relationship Between Sparrow Hawk and a Burrowing Owl
A.	Mutualism	Predation
B.	Commensalism	Predation
C.	Mutualism	Interspecific competition
D.	Commensalism	Interspecific competition

Answer: D

Outcome: D2.1k, D2.3s

Cognitive level: C/A

Use the following information to answer questions 100 to 102.

In heavily populated regions of Canada, the landscape is now dominated by what scientists call invasive, non-native species that establish themselves as a climax community. One such species, the Norway maple, has a dense rooting system, reaches sexual maturity quickly, and spreads many seeds over a wide area.

- 100.** The process by which regions of Canada become populated by the Norway maple is
- A.** primary succession, in which Norway maple replaced native species
 - B.** secondary succession, in which Norway maple replaced native species
 - C.** primary succession, in which Norway maple inhabited an area where no vegetation previously existed
 - D.** secondary succession, in which Norway maple inhabited an area where no vegetation previously existed

Answer: B

Outcome: D2.3k, D2.1sts

Cognitive level: C/A

- 101.** Which of the following rows describes two characteristics that support the Norway maple as a species with a high biotic potential?

Row	Characteristic 1	Characteristic 2
A.	Dominates the landscape	Reaches sexual maturity early
B.	Reaches sexual maturity early	Produces many seeds
C.	Has a dense rooting system	Dominates the landscape
D.	Spreads seeds over a large area	Has a dense rooting system

Answer: B

Outcome: D3.2k

Cognitive level: C/A

Use the following additional information to answer question 102.

Another invasive species, such as pampas grass, relies on other organisms to remove or harvest other native plants before they proceed to dominate the landscape.

- 102.** The relationship between pampas grass and other native plants is **best** described as
- A. parasitism
 - B. commensalism
 - C. interspecific competition
 - D. intraspecific competition

Answer: C

Outcome: D2.1k, C2.3s

Cognitive level: C/A

Use the following information to answer numerical-response question 25.

The lodgepole pine forests of British Columbia are currently being threatened by infestations of mountain pine beetles. An infested lodgepole pine becomes progressively damaged by the feeding activities of the rapidly growing beetle population in the tree. A secondary infection by fungi eventually kills the tree. Early detection of beetle-infested trees and their removal by selective logging would affect the population of both lodgepole pines and mountain pine beetles.

A Population of Mountain Pine Beetles on a Lodgepole Pine

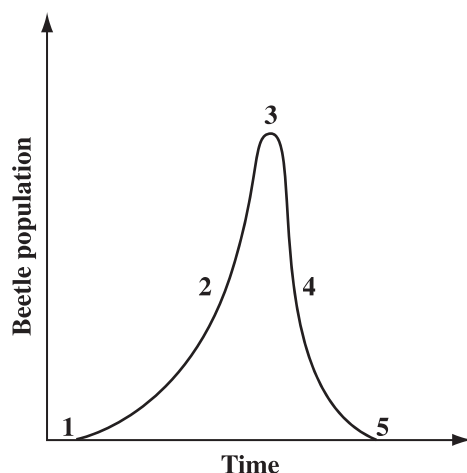

Three Equations Representing Population Change

- A (Immigration + Natality) = (Emigration + Mortality)
- B (Immigration + Natality) < (Emigration + Mortality)
- C (Immigration + Natality) > (Emigration + Mortality)

Numerical Response

25. Match three of the regions numbered on the graph above with the letters of the equations representing population change below.

Number: _____
Equation: A B C

Answer: 342
Outcome: D3.1k, D3.3k, D3.3s
Cognitive level: C/A

Use the following information to answer questions 103 and 104.

Researchers studied a red-winged blackbird nesting site. There were 208 red-winged blackbirds counted in the initial population. The following chart shows the numbers of births, deaths, and red-winged black birds entering and leaving the area over a period of 2 years.

	End of Year 1	End of Year 2
Births	22	43
Deaths	4	7
Birds entering area	0	2
Birds leaving area	2	5

- 103.** A conclusion about this study is that the red-winged blackbird population increased because
- A.** natality and immigration exceeded mortality and emigration
 - B.** mortality and emigration exceeded natality and immigration
 - C.** natality and emigration exceeded mortality and immigration
 - D.** mortality and immigration exceeded natality and emigration

Answer: A

Outcome: D3.1k, D3.3s

Cognitive level: C/A

Use the following additional information to answer question 104.

Both the red-winged blackbird and the mallard duck occupy wetland areas. Gause's principle states that when two different populations occupy the same ecological niche, one of the populations will be eliminated.

- 104.** The red-winged blackbird and the mallard duck can live in the same habitat because there is
- A.** little intraspecific competition for food and breeding areas
 - B.** little interspecific competition for food and breeding areas
 - C.** significant intraspecific competition for food and breeding areas
 - D.** significant interspecific competition for food and breeding areas

Answer: B

Outcome: D2.1k, D2.3s

Cognitive level: C/A

Use the following information to answer question 105.

The population of a colony of honey bees in Alberta varies seasonally as illustrated in the following graph.

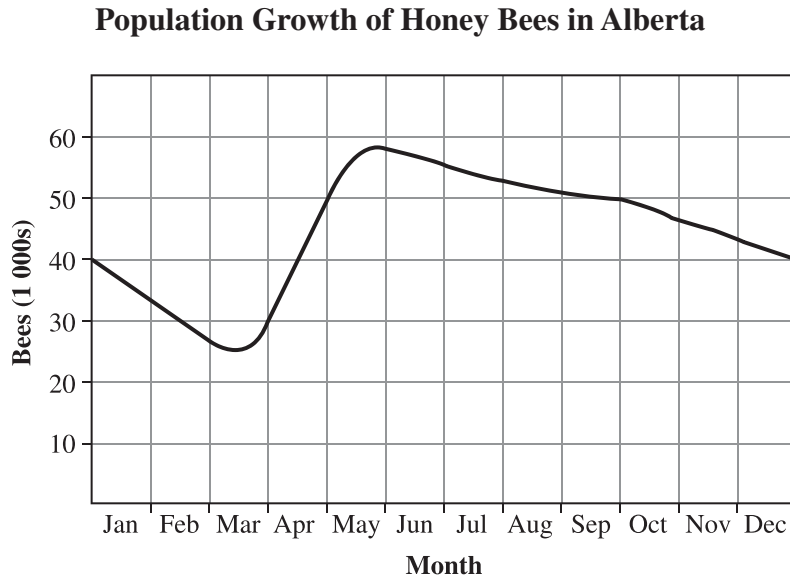

105. The portion of the graph for April **most likely** indicates the effect of

- A. an increase in parasitism
- B. a decrease in limiting factors
- C. a decrease in carrying capacity
- D. an increase in environmental resistance

Answer: B

Outcome: D3.3k, D3.3s

Cognitive level: C/A

Use the following information to answer numerical-response questions 26 and 27.

In 2001 in the North Cascades area of British Columbia, the grizzly bear population was classified as threatened. A team of scientists recommended moving grizzly bears into the North Cascades area in an attempt to save the resident population. The grizzly population in the North Cascades was estimated to be 23 bears in 2001. The goal of the recovery plan was to increase the number of grizzlies in the 9 810 km² area to 150 bears by 2050.

Numerical Response

- 26.** In the North Cascades of British Columbia in 2001, what was the density of the grizzly bear population per 1 000 km²?

Answer: _____ grizzly bears/1 000 km²

(Record your answer as a value rounded to two decimal places in the numerical-response section on the answer sheet.)

Answer: 2.34

Outcome: D3.2k, D3.3s

Cognitive level: C/A

Numerical Response

- 27.** What is the projected per capita growth rate of the grizzly bear population in the North Cascades of British Columbia from 2001 to 2050?

Answer: _____

(Record your answer as a value rounded to two decimal places in the numerical-response section on the answer sheet.)

Answer: 5.52

Outcome: D3.2k, D3.3s

Cognitive level: C/A

Use the following information to answer numerical-response question 28.

In 1999, an endangered population of 35 adult kakapo parrots inhabited Codfish Island, a small island off the coast of New Zealand. That year, 8 eggs hatched but only 6 kakapo parrot chicks survived the season and no adults died.

Numerical Response

28. In 1999, what was the per capita growth rate for kakapo parrots on Codfish Island?

Answer: _____

(Record your answer **as a value between 0 and 1 rounded to two decimal places** in the numerical-response section on the answer sheet.)

Answer: 0.17

Outcome: D3.2k, D3.3s

Cognitive level: C/A

Use the following information to answer question 106.

The Sonoran Desert in the southwestern United States has a unique climate. It has a warmer average temperature, less frequent frosts, and more rainfall than other deserts. This unique climate results in more diversity in the organisms that occupy this particular desert.

- 106.** The factors that contribute most to the diversity of organisms in the Sonoran Desert as compared with that in other deserts are
- A.** biotic factors that increase the biotic potential
 - B.** abiotic factors that reduce reproductive isolation
 - C.** abiotic factors that reduce environmental resistance
 - D.** biotic factors that increase the carrying capacity of the area

Answer: C

Outcome: D3.2k, D3.1k

Cognitive level: C/A

107. The term that describes the leveling off of a population is

- A. biotic potential
- B. a J-shaped curve
- C. carrying capacity
- D. population density

Answer: C

Outcome: D3.2k

Cognitive level: K

Use the following information to answer question 108.

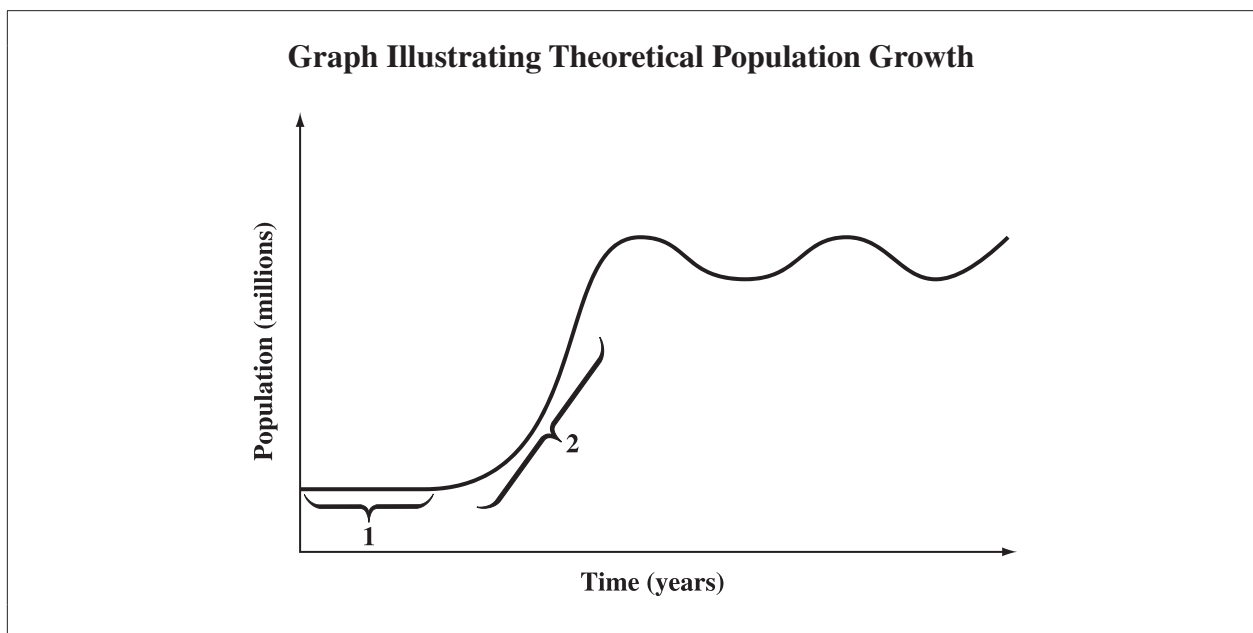

108. Which of the following rows identifies the region of the graph above that illustrates exponential growth of a population and the type of graph illustrated?

Row	Exponential Growth	Type of Graph
A.	1	S-shaped
B.	1	J-shaped
C.	2	S-shaped
D.	2	J-shaped

Answer: C

Outcome: D3.3k, D3.3s

Cognitive level: K

Use the following information to answer questions 109 to 111.

In Canada, to manage the harvesting of fish, the government issues restrictions on how many fish can be caught per fishing season based on current population estimates. Atlantic Canada cod fisheries have drawn attention to problems in the calculation of the estimates, believing that the restrictions are not high enough, and that these estimates have led to overharvesting of cod.

109. The carrying capacity for Atlantic Canada cod is **best** described as the

- A.** increase on the growth curve that shows rapid growth
- B.** increase on the growth curve that shows slow, sustained growth
- C.** decline on the growth curve that shows the cod population crashing
- D.** plateau on the growth curve that shows the cod population size stabilizing

Answer: D

Outcome: D3.3k, D3.1sts

Cognitive level: C/A

Use the following additional information to answer question 110.

The Atlantic Canada cod moratorium is a government-enforced period of no fishing.

110. Which of the following measures would be most useful when predicting the size of the Atlantic Canada cod population in the future?

- A.** Cod lifespan and natality
- B.** Cod biotic potential and future fishing quotas
- C.** Migration patterns and predator population size
- D.** Present population size and present population growth rate

Answer: D

Outcome: D3.1k, D3.2k, D3.1sts

Cognitive level: C/A

Use the following additional information to answer question 111.

Government regulators expected that Atlantic Canada's cod population would grow rapidly after the moratorium was lifted.

111. An assumption made by regulators that led them to this expectation could have been that cod
- A. have low natality and high mortality
 - B. are relatively *K*-selected with a low biotic potential
 - C. are relatively *r*-selected with a high biotic potential
 - D. have high natality and high levels of intraspecific competition

Answer: C

Outcome: D3.4k, D3.1sts

Cognitive level: C/A

Use the following information to answer numerical-response questions 29 and 30, and question 112.

Komodo Island National Park is one of the last refuges of the Komodo dragon lizard. It is estimated that there are 3 500 Komodo dragons living in the 520 km² park.

Some Characteristics of Komodo Dragons

- 1 Classified as reptiles
- 2 Can live up to 30 years
- 3 Females mate once a year
- 4 Sexually mature at about six years of age
- 5 Females lay between 20 and 30 eggs per year
- 6 The young live in trees until they are one year old
- 7 Over three metres in length and weigh up to 70 kg
- 8 Adult Komodo dragons will eat young Komodo dragons

Numerical Response

29. Four characteristics of Komodo dragons that allow scientists to classify them as relatively *K*-selected organisms are _____, _____, _____, and _____.

(Record all **four digits** of your answer **in any order** in the numerical-response section on the answer sheet.)

Answer: 2347 (Any order)

Outcome: D3.4k, D3.3s

Cognitive level: C/A

Numerical Response

- 30.** What is the population density of Komodo dragons in Komodo Island National Park?

Answer: _____ **dragons/km²**

(Record your answer **as a value rounded to two decimal places** in the numerical-response section on the answer sheet.)

Answer: 6.73

Outcome: D3.2k, D3.3s

Cognitive level: C/A

Use the following additional information to answer question 112.

Komodo dragons can have up to 50 strains of bacteria in their mouths from the meat they consume. If a deer that has been bitten by a Komodo dragon manages to escape, it will die within a week as a result of bacterial infection. Komodo dragons often locate and consume the dead deer. Komodo dragons are resistant to infection by the bacteria.

- 112.** Which of the following rows describes the relationship between the Komodo dragon and the bacteria and the relationship between deer and the bacteria?

Row	Relationship Between Komodo Dragon and Bacteria	Relationship Between Deer and Bacteria
A.	Mutualism	Predation
B.	Parasitism	Predation
C.	Mutualism	Parasitism
D.	Parasitism	Parasitism

Answer: C

Outcome: D2.1k, D2.3s

Cognitive level: C/A